

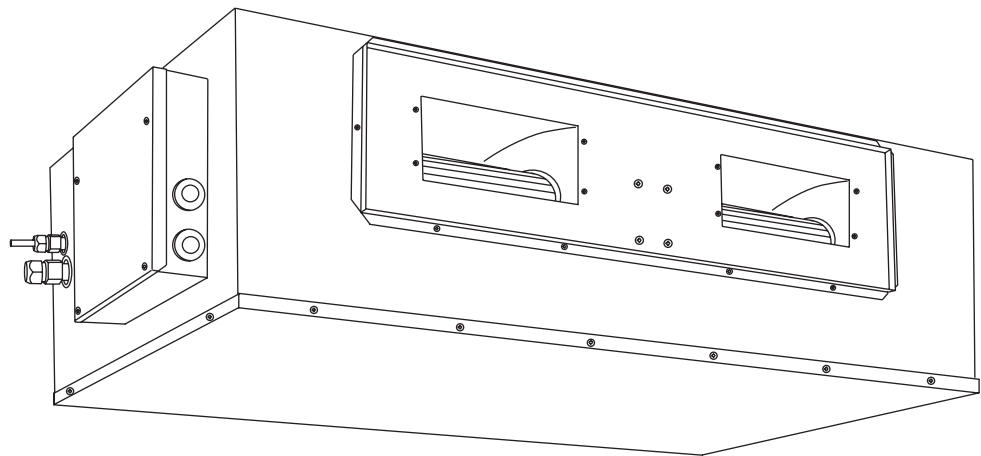

SERVICE MANUAL

## T-series Ducted Air Conditioner

---



- **T410-115DU** 12kW Ducted System
- **T410-140DU** 15kW Ducted System

# Contents

---

1. Important notice .....	3
2. Technical specifications .....	4
3. Wall controller operation .....	5
4. Remote controller operation .....	6
5. Operation details.....	7
6. Wiring controller installation .....	12
7. Wiring diagrams .....	13
8. Explosion views and part lists.....	15

## Important notice

---

This service manual is intended for use by individuals possessing adequate backgrounds of electrical, electronic and mechanical experience. Any attempt to repair the appliance may result in personal injury and property damage. The manufacturer or seller cannot be responsible for the interpretation of this information, nor can it assume any liability in connection with its use.

The information, specifications and parameter are subject to change due to technical modification or improvement without any prior notice. The accurate specifications are presented on the nameplate label.

### How to order spare parts

To have your order filled promptly and correctly, please furnish the following information:

1. Model number with indoor or outdoor
2. Number in the explosion view
3. Part name
4. The quantity you require

## Technical specifications

Model no.	T410-115DU		T410-140DU
Type	Fixed speed		Fixed speed
Control type	LCD remote controll and LCD wall controller		
Static pressure	Standard	Pa	50
	Range	Pa	50~180
Cooling capacity	Btu/h;W		36000; 11500
Heating capacity	Btu/h;W		38000; 12000
EER for cooling	Btu/h.w; W/W		8.78; 2.76
COP for heating	Btu/h.w; W/W		10.9; 3.46
Indoor noise level at cooling (sound pressure level)	High	dB(A)	53
	Med.	dB(A)	52
	Low	dB(A)	51
Outdoor noise level (sound power level)	dB(A)		65

### Electrical data

Power supply	220-240V~/50Hz/1P		220-240V~/50Hz/1P
Voltage range	V		198~254
Current	Cooling	A	18.0
	Heating	A	17.4
Power input	Cooling	W	4150
	Heating	W	4000
Max. power	W		5865
Max. current	A		25.5

### Refrigerating system

Refrigerant/charge	R410A/3400g		R410A/4000g
Evaporator	Hydrophilic & Louver Fin; Innergroover tube type (φ9.52)		
Condenser	Hydrophilic & Louver or Corrugated Fin; Innergroover tube type (φ7)		
Expansion device	Capillary tube		
Defrosting system	Microcomputer controlled reverse system		

### Fan system

Outlet size of indoor airflow	mm	855×220	855×220
Returning vent size of indoor airflow	mm	1096×310	1096×310
Indoor air circulation (cooling/heating)	L/S	695/630/630	750/667/667
	m <sup>3</sup> /h	2500/2270/2270	2700/2400/2400
Indoor fan type	Centrifugal		Centrifugal
Outdoor fan type	Propeller		Propeller

### Connections

Refrigerant coupling	Flare		Flare
Connecting pipe	Liquid	Inches	1/2 "
	Gas	Inches	3/4 "
Max. height drop (high head)	m		10
Max. length of connecting pipe	m		25
Max. pipe length with standard charge	m		5
Refrigerant charge with long pipe	g/m		110
Drainage pipe	mm		O.D 16

### Size and weight

Net dimensions (W x H x D)	Indoor	mm	1200×380×590	1200×380×590
	Outdoor	mm	950×1255×410	1000×1510×400
Net weight	Indoor	kg	55	58
	Outdoor	kg	112	132
Packing dimension (W x H x D)	Indoor	mm	1410×445×695	1410×445×695
	Outdoor	mm	1030×1380×440	1135×1645×440
Gross weight	Indoor	kg	60	63
	Outdoor	kg	122	145

#### Note: specifications are based on the following conditions:

Cooling: Indoor temperature 27°C DB/19°C WB, and outdoor temperature 35°C DB/24°C WB

Heating: Indoor temperature 20°C DB/15°C WB, and outdoor temperature 7°C DB/6°C WB

Equivalent piping length: 5m, Level difference: 0m, Voltage: 220V

Sound Level: Indoor unit sound pressure level, measured at a point 1.5m downward from the unit centre

Outdoor unit sound pressure level, measured at a point 1.0m in front of the unit

Due to ongoing product development, specifications are subject to change without prior notice

**WU`V&bfc`Yf'cdYfUjcb**

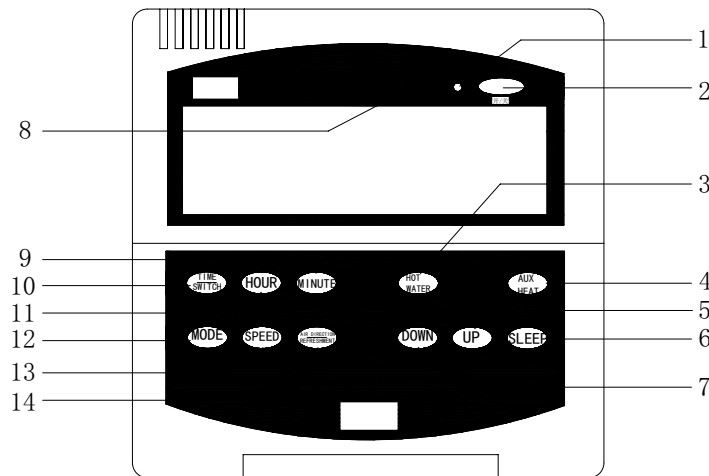

● Button Description:

- 1 Power indicator    2 Power on/off    3 Hot water (Exclusive for double-energy unit)
- 4 Aux Heat    5 Up    6 Sleep    7 Down    8 Remote Signal Receiver
- 9 Minute    10 Timer    11 Hour    12 Mode    13 Fan Speed
- 14 Air Direction/refreshment

LCD Screen

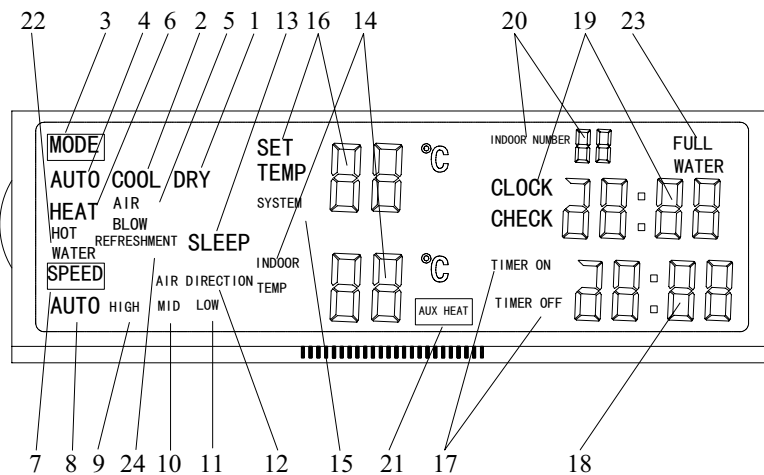

- 1. DRY 2. Cooling 3. Mode Mark    4. Auto
- 5. FAN mode    6. Heating 7. Fan speed mark    8. Auto Fan Speed
- 9. High air speed    10. Medium air speed    11. Low air speed
- 12. Wind Direction Mark
- 13. SLEEP mark    14. Temp Display(invisible)    15. SYSTEM mark(reservation)
- 16. Setting Temp Display    17. LOCK mark    18. TIMER mark
- 19. TIME    20. wire controller extension number (reservation)
- 21. Aux Heat Operation Mark    22. Hot Water mode (reservation)    23. Full Water mark
- 24. Refreshment Mark

# REMOTE CONTROLLER OPERATIONS

## Parts of Names & Functions

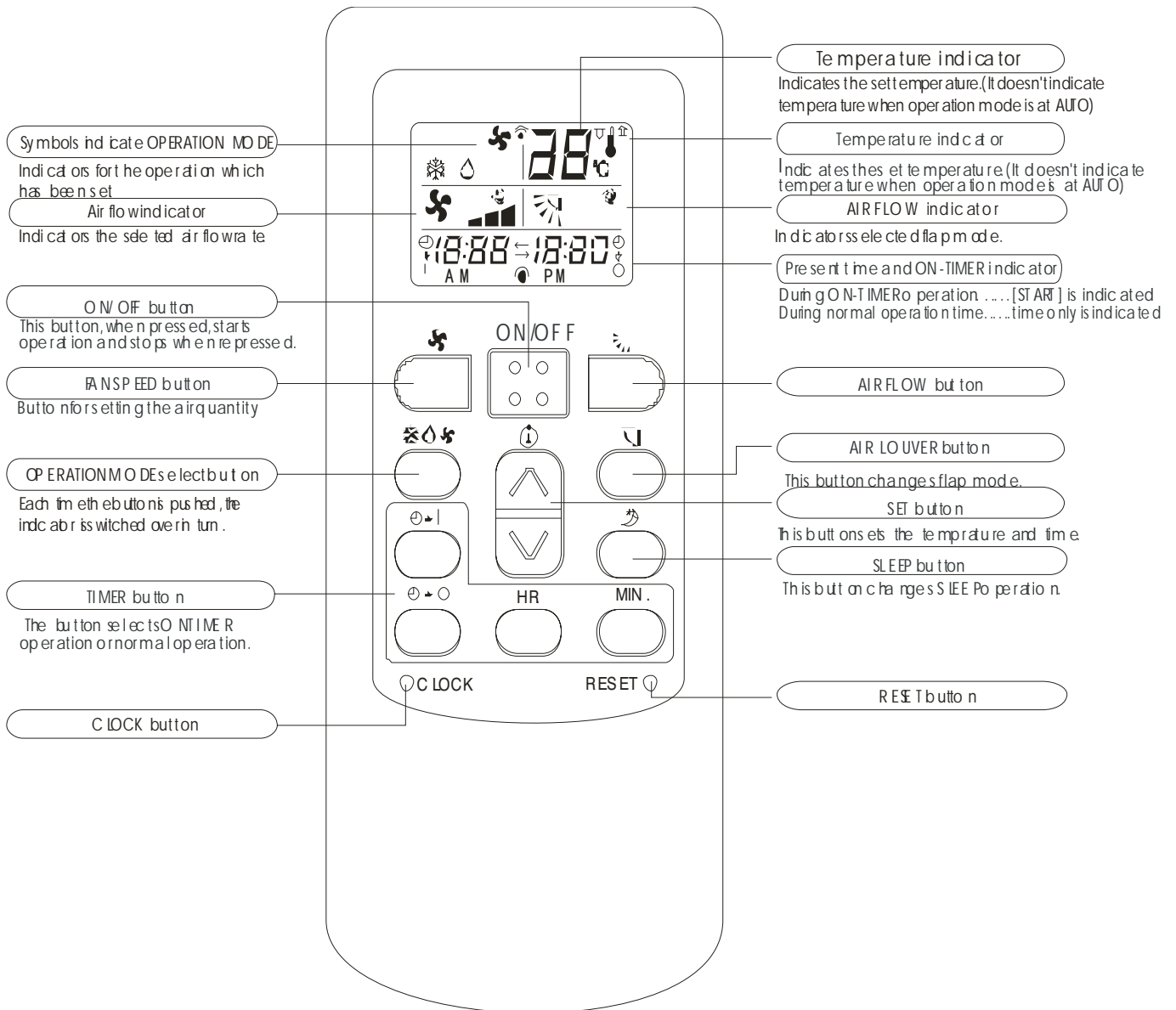

## CdYfUjcb'8 YHJ`g

### 1. Safety Protection

#### (1) Time Delay for Safety protection

- 3 minutes delay for compressor ---The compressor is ceased for 3minutes before restarting to balance the pressure in the refrigeration cycle in order to protect the compressor.
- 2 minutes delay for 4-way valve---The 4-way valve will be ceased for 2 minutes late after compressor to prevent the refrigerant-gas abnormal noise when the HEATING operation is OFF or switch to the other operation mode.

#### (2) Discharge temperature protection

There is a temperature sensor on top of compressor, when temperature on top of compressor exceeded the limit, system control will shut down the compressor and the display board will show the error code.

#### (3) lower voltage protection

When AC voltage  $\leq 158V$  and keep it for 10 seconds, unit will be shut down for protection.

#### (4) Over voltage protection

When AC voltage  $\geq 260V$ , unit will be shut down and recover while  $AC \leq 255V$ .

#### (5) Over current protection

When the current of outdoor unit is overload, controller shut down the unit immediately and show error code.

#### (6) Compressor abnormality protection

When compressor start on or in the process of running, if there is no feedback to controller or load of compressor is abnormality, the air conditioner will shut down, and show error code.

#### (7) IPM module protection

IPM module has high temperature & over current protection itself, if there is signal feedback to IPM, the outdoor unit will shut down, LED on outdoor PCB will show the error code.

### 2. "I Feel" Mode Operation

(1) When the "I Feel" mode is selected, the operation mode and initial temperature set are determined by the initial room temperature at start-up of the operation except to turn off the air conditioner and operates it again.

(2) If the mode is change to "I Feel" from other mode, the "I Feel" mode doesn't operate until compressor stop for more than 3 minutes.

Mode	Initial Room Temperature	Initial Set Temperature
COOLING	$RT \geq 26^{\circ}C$	$23^{\circ}C$
DRY	$26^{\circ}C > RT \geq 20^{\circ}C$	$RT - 2^{\circ}C$
HEATING for Heat Pump FAN for Cooling Only	$RT < 20^{\circ}C$	-

- In the "I Feel" mode, when the controller receives the up or down signal of temperature, the set temperature can adjust by  $1^{\circ}C$  upper or lower. The biggest you can adjust by  $2^{\circ}C$  upper or lower.

### 3. "COOLING" Mode Operation

## (1) Compressor frequency control

According to difference room temperature and set temperature ( $\delta t = RT - ST$ ), running frequency of compressor is controlled by electronic controller. When room temperature is much higher than set temperature, compressor will start at a high frequency, and as room temperature goes down, compressor running frequency will go down. When room temperature is lower than set temperature, compressor will run at very low frequency. In general, unit will change its running frequency according to  $\delta t$  to make room temperature closing to set temperature.

## (2) Outdoor temperature affects running frequency of compressor

Outdoor temperature affect compressor's running frequency. Difference inlet temperature of outdoor unit is adapted by difference compressor running frequency. While outdoor temperature is about 30°C, the compressor will run in high frequency.

If unit run in "cooling" mode and outdoor temperature is less than -1°C, controller will shut down compressor and show error code, while the ambient temperature is over 0°C, the compressor will run automatically.

## (3) Auto fan control in cooling mode

In cooling mode (include cooling in "I feel" mode), fan speed is determined by  $\delta t$ , as the following diagram:

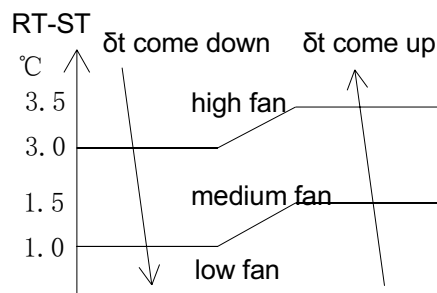

## 4. "DRY" Mode Operation

- (1) The system for DRY operation used the same refrigerant circle as the cooling one.
- (2) When the system operates in DRY mode, at first it operates in cooling mode at 16°C or 18°C for 3 minutes. After that, the system will operate in cooling mode with lowest fan speed, meanwhile the set temperature (**ST**) is "RT-2°C" which means that the ST is room temperature at then minus 2. During the course of this mode, the fan speed set operation and room temperature set are restricted, except the vane motor adjusting.

## 5. "HEATING" Mode Operation (available for Heat Pump only)

## (1) Frequency control

The same as the frequency control in cooling mode, running frequency of compressor is controlled by controller. Unit change its running frequency according to  $\delta t$  to make room temperature closing to the set temperature.

## (2) Indoor fan motor control

## 1. Cold Air Prevention Control

- The function is intended to prevent cold air from being discharged when the heating operation starts or when defrosting.
- The indoor fan speed will be controlled as following.

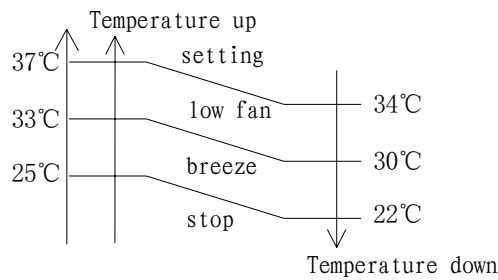

- In the heating operation, if the air conditioner is turned off, the indoor fan motor will run most for 30 seconds since the stop of compressor.

## 2. Auto fan control (heating)

In heating mode(include in "I feel" mode) , fan speed is determined by  $\delta t$ , as the following:

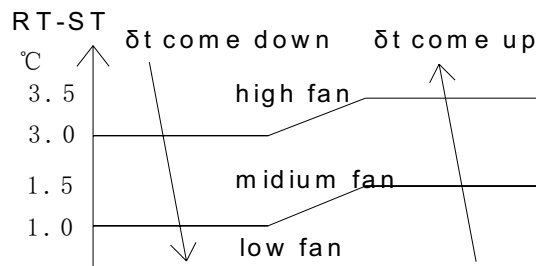

## (3) 4-way valve control

In heating mode, 4-way valve will power on ahead of compressor for 5 seconds, and cut off for 2 minutes later than compressor's stop. 4-way valve will not power off unless the machine is switched off, mode changed or on the process of defrosting.

## (4) Defrosting

Defrosting is controlled by the microprocessor.

When one of the following conditions is satisfied, unit will come into defrosting:

- Outdoor heat exchanger Temperature (OPT) is continuously less than 3°C while the unit runs for more than 40 minutes, and OPT is keeping under -6°C for more than 3 minutes.
- Outdoor heat exchanger Temperature (OPT) is continuously less than 3°C meanwhile the unit runs for more than 80 minutes, and OPT is keeping under -4°C for more than 3 minutes.
- Outdoor heat exchanger Temperature (OPT) is continuously less than 3°C while the unit runs for more than 120 minutes, and OPT is keeping below -2°C for more than 3 minutes.

Before the air con come into defrosting, compressor running frequency drop down to a lower frequency firstly, then the compressor shuts down.

In defrosting, the max. frequency of compressor is F9 (a little less than the highest frequency). In this period all protection function are available.

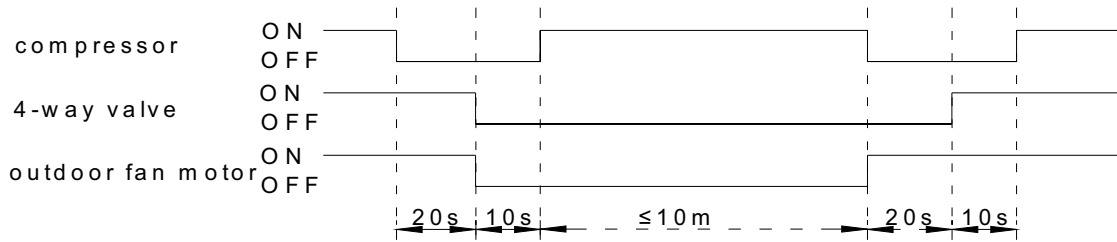

In defrosting, LED showing by winking.

Come into or out of defrosting, indoor fan motor speed is the same as Cold Air Prevention Control.

One of the following conditions is satisfied, unit come out of defrosting and shift to heating mode:

- a. Outdoor coil Temperature (OPT)  $\geq 15^{\circ}\text{C}$
- b. Defrost time keep time for more than 10 minutes.

#### (6) Indoor exchanger overheat protection

When Indoor exchanger Temperature(IPT) is higher than  $55^{\circ}\text{C}$ , unit come into indoor exchanger overheat protection. Compressor drop its frequency toward to F1 level until  $\text{IPT} \leq 52^{\circ}\text{C}$ ; If  $\text{IPT} \leq 52^{\circ}\text{C}$  and keep for 5 minutes, control system don't limit running frequency.

If  $\text{IPT} > 62^{\circ}\text{C}$ , control system shut down compressor, and recover when IPT drop less than  $50^{\circ}\text{C}$ .

### 6. "SLEEP" mode

When the SLEEP button is pressed, the SLEEP mode is selected as following:

- The indoor fan speed is set at low speed, the power lamp and the sleep lamp is on, the display of temperature will be close after 5 minutes.
- When selecting COOLING/DRY operation with SLEEP mode, the set temperature will be raised by  $1^{\circ}\text{C}$  1 hour later and by  $2^{\circ}\text{C}$  2 hour later.
- When selecting HEATING operation with SLEEP mode, the set temperature will be dropped by  $1^{\circ}\text{C}$  1 hour later and  $2^{\circ}\text{C}$  2hour later.
- After the System operates in SLEEP mode for 8 hours, it will stop automatically.

### 7. EMERGENCY Operation

When the EMERGENCY Operation switch is pressed once, COOLING mode is selected and if in 3 seconds the EMERGENCY Operation switch is pressed again, mode is selected. Then pressed once again, the unit is switch off.

When the remote controller is missing, has failed or the batteries run down, press the EMERGENCY Operation switch on the front of the indoor unit. The unit will start.

The first 30 minutes of operation will be the test run operation. The operation is for servicing. The indoor fan runs at high speed and the system is in continuous operation. The thermostat is ON and the timer is reset to normal.

After 30 minutes of test run operation the system shifts to AUTO COOLING/HEATING mode, and the indoor fan runs in automatic speed. The operation continues unit the EMERGENCY operation switch is pressed or a button on the remote controller is pressed, the normal operation will start.

NOTE: Do not press the EMERGENCY Operation switch during normal operation.

### 8. AUTO-RESTART Function (Option)

1. When air conditioner is operating in one mode, all of its operation data, such as working mode and temperature of setup would be memorized into IC by main PCB. If power cuts due to

some reason, when power supply come back again, the AUTO-RESTART function will set synchronously and automatically to work. So the air conditioner would work at the same mode before.

**Auto-restart Pre-setting (optional):**

If Auto-restart function is needed, follow the steps below to activate this function:

- 1) Pulling the air-con's plug out of socket.
- 2) Pressing and holding the Emergency button (ON/OFF) on the indoor, then insert the plug into the socket again.
- 3) Keep pressing the Emergency button for more than 10 seconds until three short beeps are heard. The **Auto-restart** function has been started.

**9. Protection and Failure Display**

- When protection display is available, controller will show error code, digital LED shows error code and setting temperature by turns.
- If there is more than one failure, it will show at first that in front of the error list.
- Protection display function can be selected in hardware, and the default don't display;
- To insure of in and out communist is credibility, the failures relate to outdoor unit will remain failure state for 2 minutes max after recovered.
- In all failures, only sensor failures don't have to repower to cancel.

### Wiring controller installation

3-bored control pad program and 6-bored control pad program can be compatible in the wire controller. When dialing code switch SW1 at the back of wire controller is moved to "NO",

3-bored control pad program is chosen; when it is moved to "OFF", 6-bored control pad program is chosen.

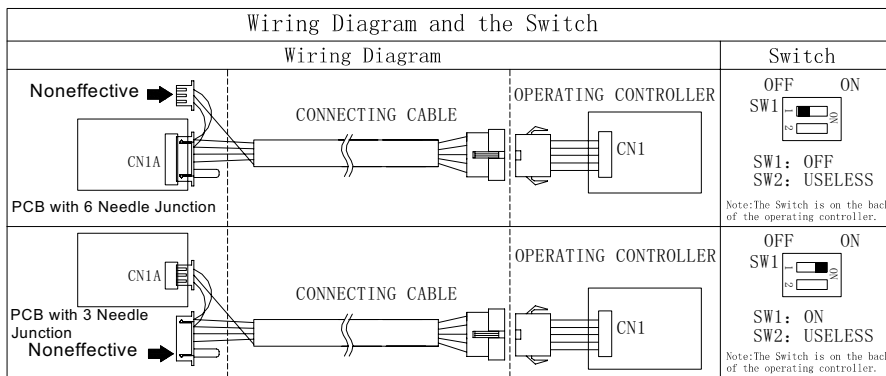

### Wiring Display Instruction

When any trouble occurs in the electric circuit, LCD display code of trouble, the relationship of code and trouble can be listed as following:

Priority	Code Display	Byte Data2	Trouble
1	E2	02	Outdoor Protection ( recoverable )
2	E6	06	Wire controller and control pad communication ( recoverable )
3	E7	07	Room Temp sensor abnormal ( recoverable )
4	E8	08	Condensor sensor abnormal ( recoverable )
5	E9	09	Evaporator sensor abnormal ( recoverable )
6	EE	0E	EEPROM communication abnormal(recoverable when power is on again)

# Wiring diagram

## Indoor unit

T410-115DU, T410-140DU

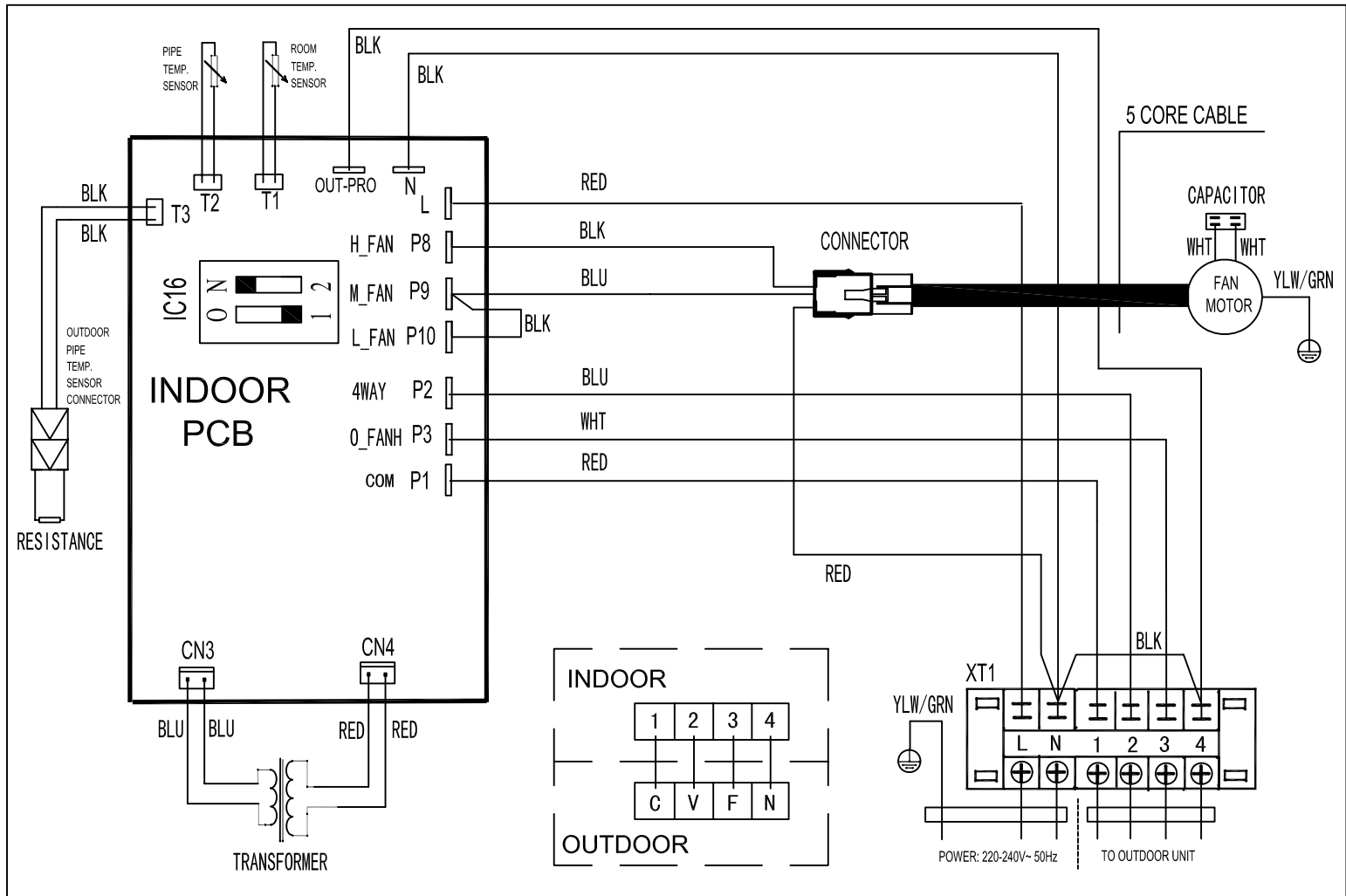

# Wiring diagram

Outdoor unit

T410-115DU, T410-140DU

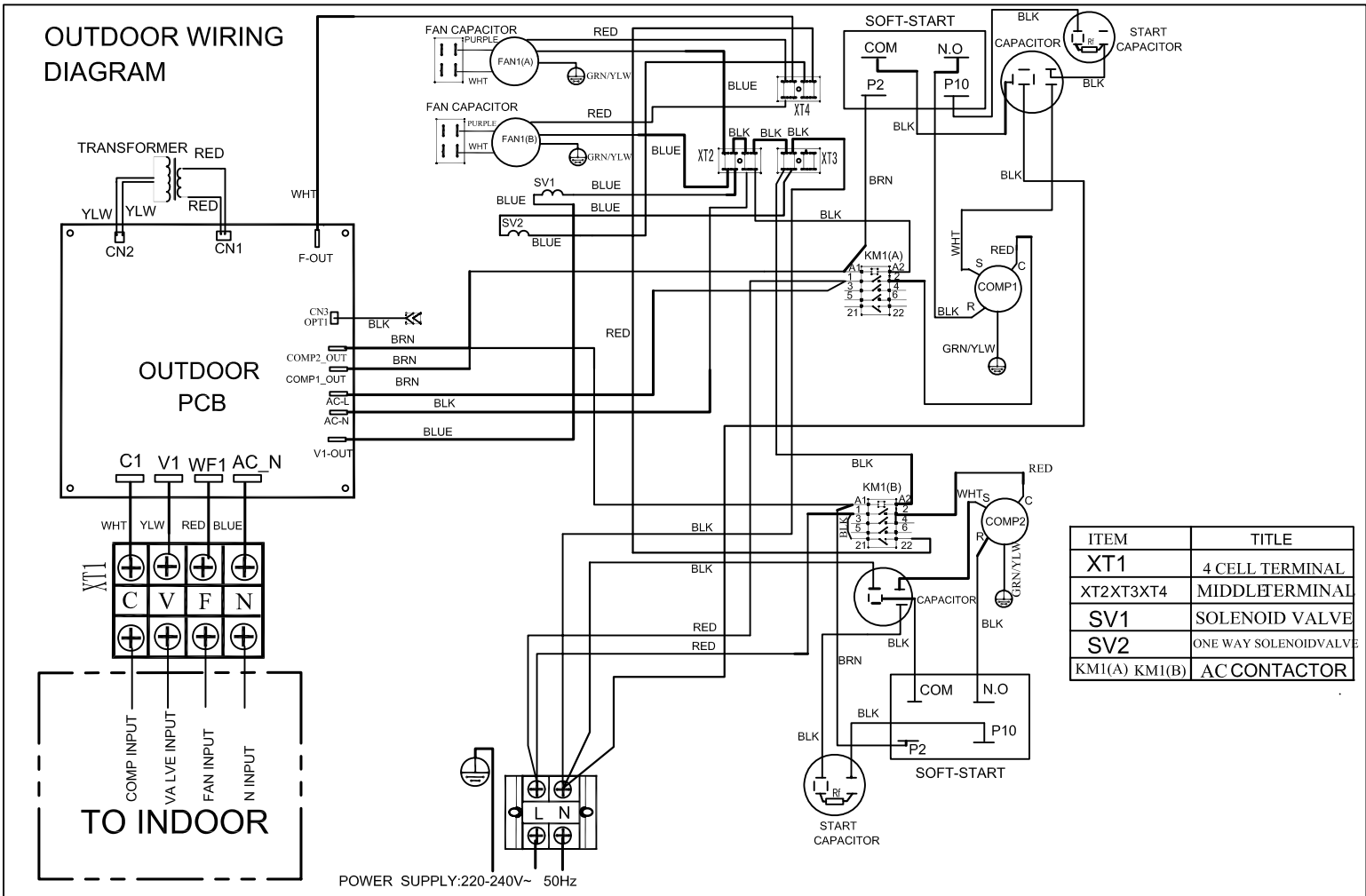

### Explosion view

### Indoor unit

Model: "V632/337F W."V410-140DU

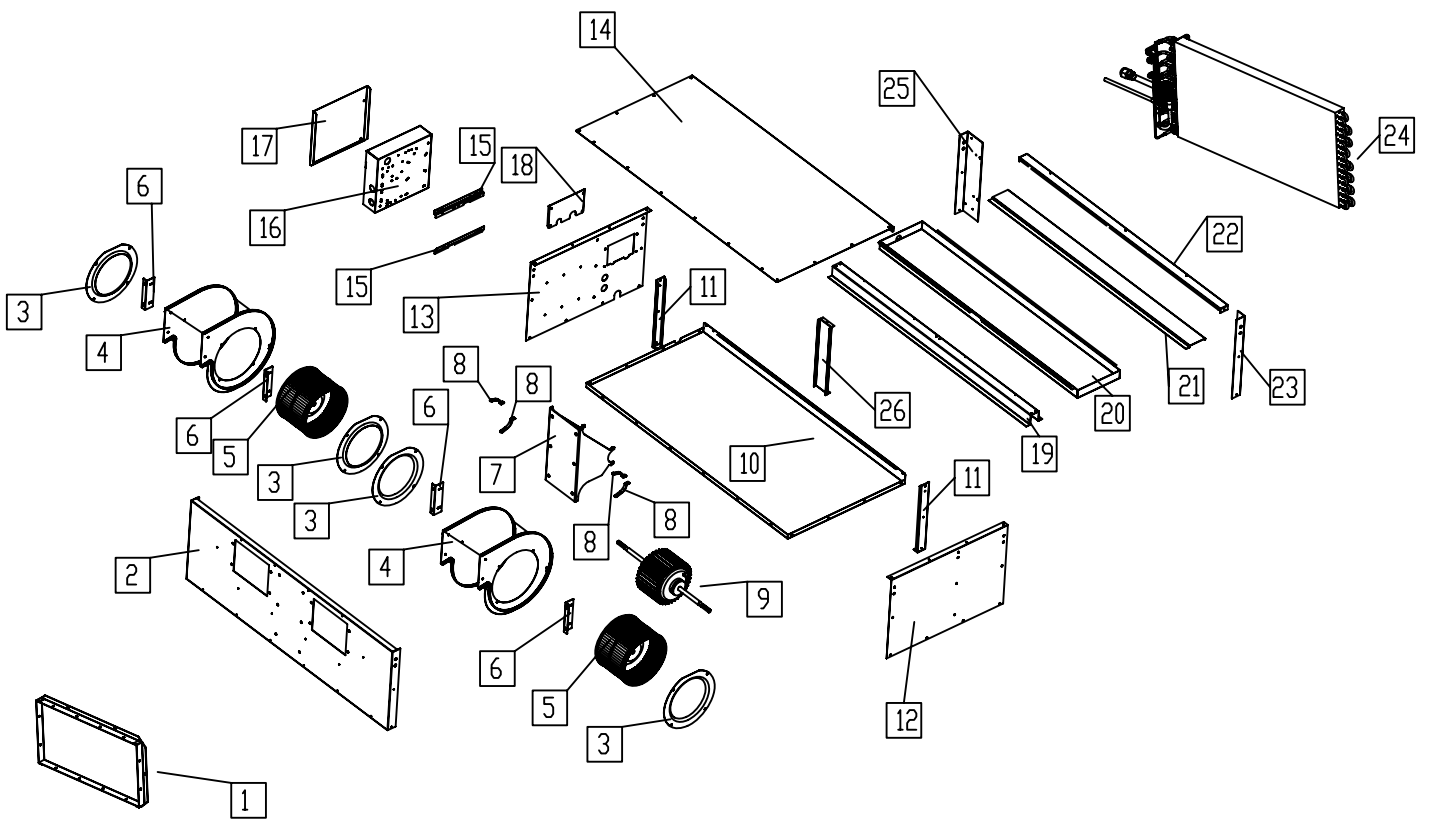

## Spare part list

## Indoor unit

Model: "V632/337F W."T410-140DU

<b>NO.</b>	<b>Part Name</b>	<b>Part NO.</b>	<b>Remark</b>	<b>Q'ty</b>
1	air outlet subassembly	3084555108		1
2	air outlet assembly	3084584314		1
3	circle of air director	3084554845		1
4	scroll assembly	3084537112		1
5	fan	3074537101		2
6	scroll fix board	3084535915		1
7	fan motor bracket	3084554835		1
8	fan motor clamp	3084554842		1
9	indoor fan motor	3174555101		1
10	down plate	3084557001		1
11	beam	3084555106		1
12	right side barrier	3084557003		1
13	left side barrier	3084557002		1
14	top cover	3084557011		1
15	electronic box bracket	3084554831		1
16	electric controller box	3084554843		1
17	electronic box cover	3084554867		1
18	fix pipe board	3084554838		1
19	fix drip tray bar	3084555118		1
20	drip tray	3084557010		1
21	drip tray airproof	3084555116		1
22	top crossbeam	3084555101		1
23	left corner knighthed	3084554834		1
24	evaporator subassembly	3114555101		1

Explosion view

Outdoor unit

Model: T410-115DU, T410-140DU

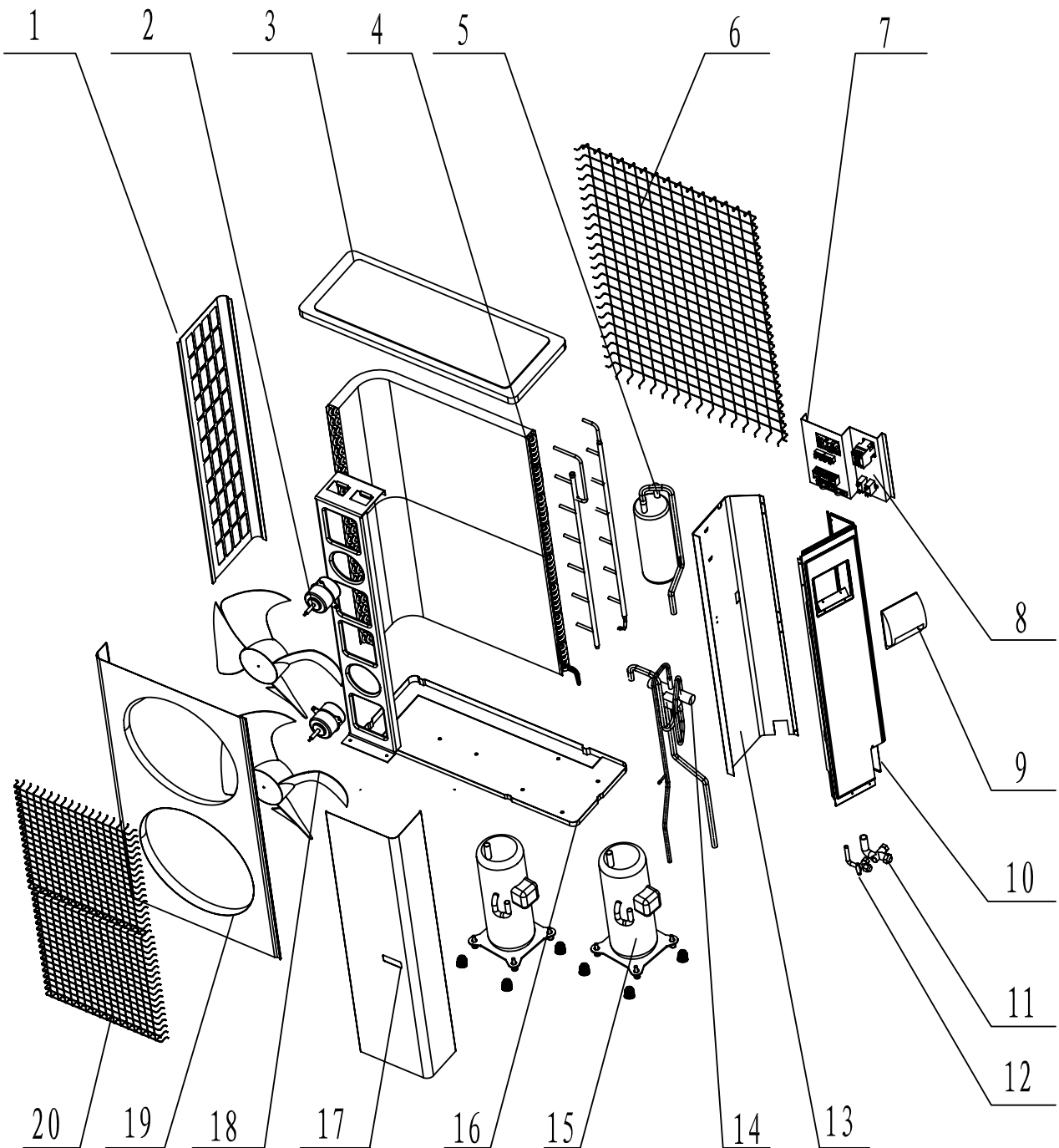

## Spare part list

## Outdoor unit

Model: T410-115DU, T410-140DU

NO.	Part NO.	Material Name	Remark	Quantity
1	Left protection net	3212510108		1
2	Outdoor Motor	3173010110	YDK70-6	1
3	Supproter of Outdoor Motor	3083010127	1510×225×t1.5	1
3	Top Cover	3082510701	2HC/HO.00-03	1
4	Upper Condenser 1 subassembly	3112600202		1
	Lower Condenser 2 subassembly	3112600201		1
5	Accumulator	3120160019	ZYG-19	1
6	Back Net	3083010111		1
7	Electronic control box assembly	3083010137		1
8	Outdoor PCB	3092600201		1
	Outdoor softstart PCB	3172512602		2
9	Handle	3073010103		1
10	Right plate	3212600201		1
11	3-way Valve (gas valve)	3120130039	DYF-35 φ19.05	1
12	2-way Valve (liquid valve)	3120120014	2 3/4 "-16UNF	1
13	Partition plate	3212600208		1
14	Winding of 4-way valve	3172510101		1
	4-way valve	3120110001		1
15	Compressor	3100060490		2
16	Base subassembly	3087010201		1
17	Right front panel	3217010112		1
18	Outdoor Axial fan	3070030002		1
19	Lift front panel	3083010104		1
20	Air outlet griller	3082510124		1
23	Transformer	3171990142		1
24	AC Contact	3171990004		2
25	Cable clamp( Terminal)	3170200005		1
26	Clamp	3071990016		1
27	Capacitor for compressor	3170100004	Not shown in explosion view	1
28	Capacitor for compressor soft start	3170100031		1
29	Capacitor for fan motor	3170100010		1
30	Condenser sensor	3160130006		1
				1