

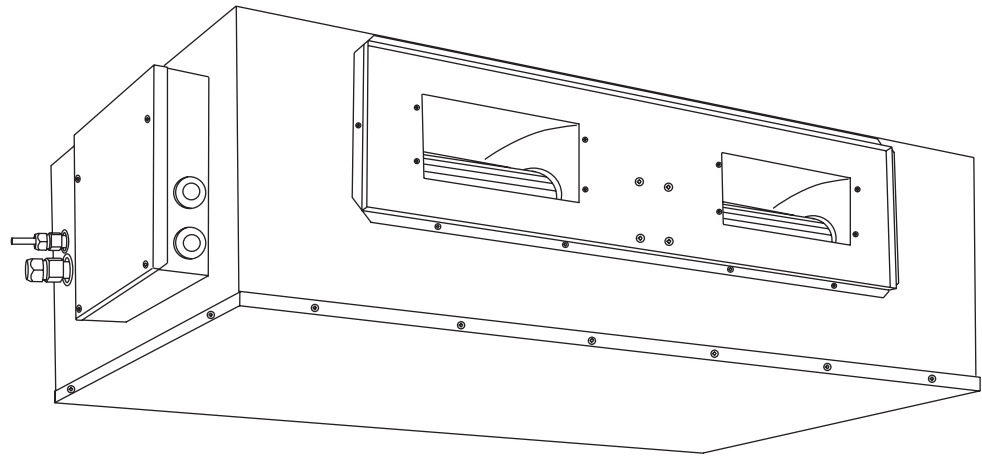

USER MANUAL

T-series Ducted Air Conditioner





- **T410-115DU** 12kW Ducted System
- **T410-140DU** 15kW Ducted System

CONTENTS

PRECAUTION	1
PARTS AND FUNCTIONS	3
REMOTE CONTROLLER OPERATION	4
TROUBLES AND CAUSES ABOUT REMOTE CONTROLLER	9
IMPORTANT SAFETY INFORMATION	9
INDOOR UNIT INSTALLATION	11
OUTDOOR UNIT INSTALLATION	14
REFRIGERANT PIPE INSTALLATION	15
DRAINAGE PIPE INSTALLATION	16
ELECTRIC WIRING	17
TRY TEST	19
TROUBLESHOOTING	20
CAPACITY CORRECTION FACTOR	20
AIR FLOW AND STATIC PRESSURE	22
SPECIFICATION	23

PRECAUTION

- Read the following " PRECAUTIONS" carefully before installation.
- The caution items stated here must be followed because these important contents are related to safety. The meaning of each indication used is as below.
Incorrect installation due to ignoring of the instruction will cause harm or damage, and the seriousness is classified by the following indications.

 WARNING	This indication shows the possibility of causing death or serious injury.
 CAUTION	This indication shows the possibility of causing injury or damage to properties only.

NOTE :

1. Injury means causing harmed, burned, electrical shocked, but not serious for hospitalization.
 2. Damage of property means disrepair of property, material.
- Carry out test running to confirm that no abnormality occurs after the installation. Then, explain to user the operation, care and maintenance as stated in instructions. Please remind the customer to keep the operating instructions for future reference.

 WARNING
<ul style="list-style-type: none"> • Engage dealer or specialist for installation. If installation done by user is defective, it will cause water leakage, electrical shock or fire.
<ul style="list-style-type: none"> • Install according to this installation instructions strictly. If installation is defective, it will cause water leakage, electrical shock or fire.
<ul style="list-style-type: none"> • Use the attached accessories parts and specified parts for installation. Otherwise, it will cause the set to fall, water leakage, fire or electrical shock.
<ul style="list-style-type: none"> • Install at a strong and firm location which is able to withstand the set's weight. If the strength is not enough or installation is not properly done, the set will drop and cause injury.
<ul style="list-style-type: none"> • For electrical work, follow the local national wiring standard, regulation and this installation instructions. An independent circuit and single outlet must be used. If electrical circuit capacity is not enough or defect found in electrical work, it will cause electrical shock or fire.
<ul style="list-style-type: none"> • When carrying out piping connection, take care not to let air or other substances other than the specified refrigerant go into refrigeration cycle. Otherwise, it will cause lower capacity, abnormal high pressure in the refrigeration cycle, explosion and injury.
<ul style="list-style-type: none"> • Grounding is necessary. It may cause electrical shock if grounding is not perfect.
<ul style="list-style-type: none"> • Do not install the unit at place where leakage of flammable gas may occur. In case gas leaks and accumulates at surrounding of the unit, it may cause fire.

Operating condition

The protective device maybe trip and stop the unit within temp range listed below:

HEATING	Outdoor air temperature is over 21°C
	Outdoor air temperature is below -7°C
	Room temperature is over 31°C
COOLING	Outdoor air temperature is over 43°C
	Room temperature is below 17°C
DRY	Room temperature is below 18°C

If the air conditioner runs for a long time in "COOLING" or "DRY" mode at air relative humidity higher than 80% (doors or windows opened),dew may generate and drip near air outlet.

Noise pollution

- Install the air conditioner in a place that can bear its weight in order to operate more quietly.
- Install the outdoor unit in a place where the air discharged and the operation noise do not annoy your neighbors.
- Do not place any obstacles in front of the outlet of the outdoor unit for fear it affects operation and increases the noise level.

Features of Protector

- 1 The protective device will trip at following cases.
 - Stop the appliance and restart it at once or change other modes during operation, you have to wait 3 minutes before restarting.
 - After switching on the power circuit breaker and then turn on the air conditioner at once, you have to wait about 20 seconds.
- 2 In case all operations have stopped, you need
 - Press "ON/OFF" button again to restart it.
 - Set TIMER once again if it has been canceled.

Inspection

After a long time of operation, the air conditioner should be inspected for the following items.

- Abnormal heating of the power supply cord and plug or even a burnt smell.
- Abnormal operating noise or vibration.
- Water leakage from indoor unit.
- Metal cabinet electrified .
- ✎ Stop using the air conditioner if above problem happened.
It is advisable that the air conditioner should be given a detail check-up after using for five years even if none of the above happen.

Feature of HEATING mode

Preheat

2-5 minutes are necessary to preheat the indoor heat exchanger at the beginning of "HEATING" operation, lest cold air be discharged.

Defrost

In "HEATING" operation the appliance will defrost automatically. This procedure lasts 2~10 minutes, then returns to "HEATING" mode automatically. During defrosting, indoor fan stop running and return to heating mode operation automatically when defrosting has finished.

PARTS AND FUNCTIONS

- ① Drain pan
- ② Refrigerant pipe
- ③ Centrifugal fan motor
- ④ Drain adapter
- ⑤ Air outlet
- ⑥ Electric control box
- ⑦ Remote controller
- ⑧ Line control panel
(Selected and purchased additionally)
- ⑨ Drain pipe
- ⑩ Refrigerant connecting pipe
- ⑪ Connecting cable
- ⑫ Stop valve
- ⑬ Air-outlet grill enclosure

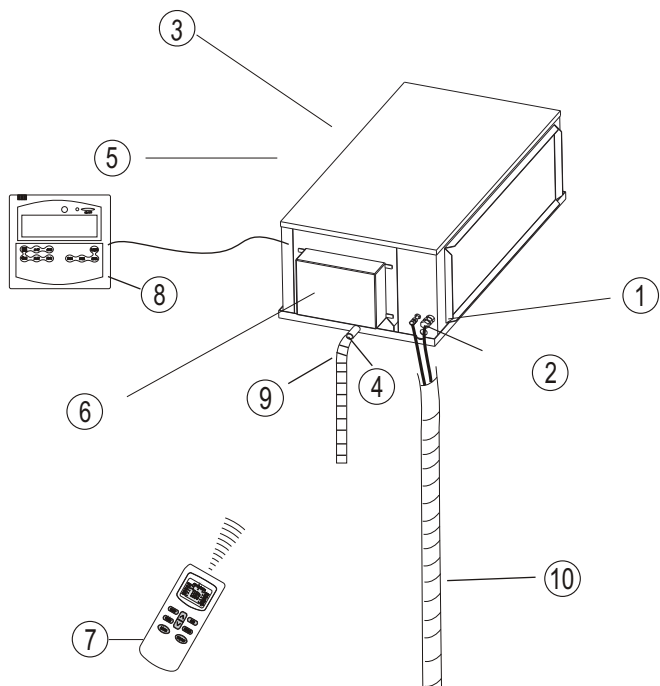

■ Outdoor unit

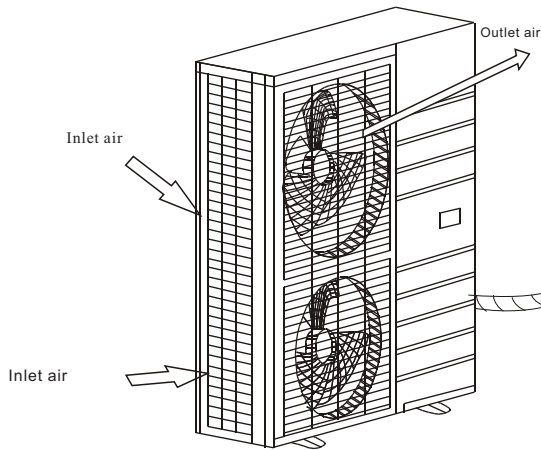

Requirements

- The air conditioner cannot be started up until it is powered on for 2 hours. Furthermore, in case of a shutdown lasting for about one diel only, please do not cut off the electricity supply. (it is necessary to heat the crankcase heater so as to avoid force start of compressor.)
- Notice that the air inlet/outlet must not be choked up. If chokeup takes place, the air conditioner behavior may be affected, or air conditioner cannot run because of actuation of protector.
- After you have installed the wire controller, the function of auto-restarted is shielded by wire controller.

REMOTE CONTROLLER OPERATION

Parts of Names & Functions

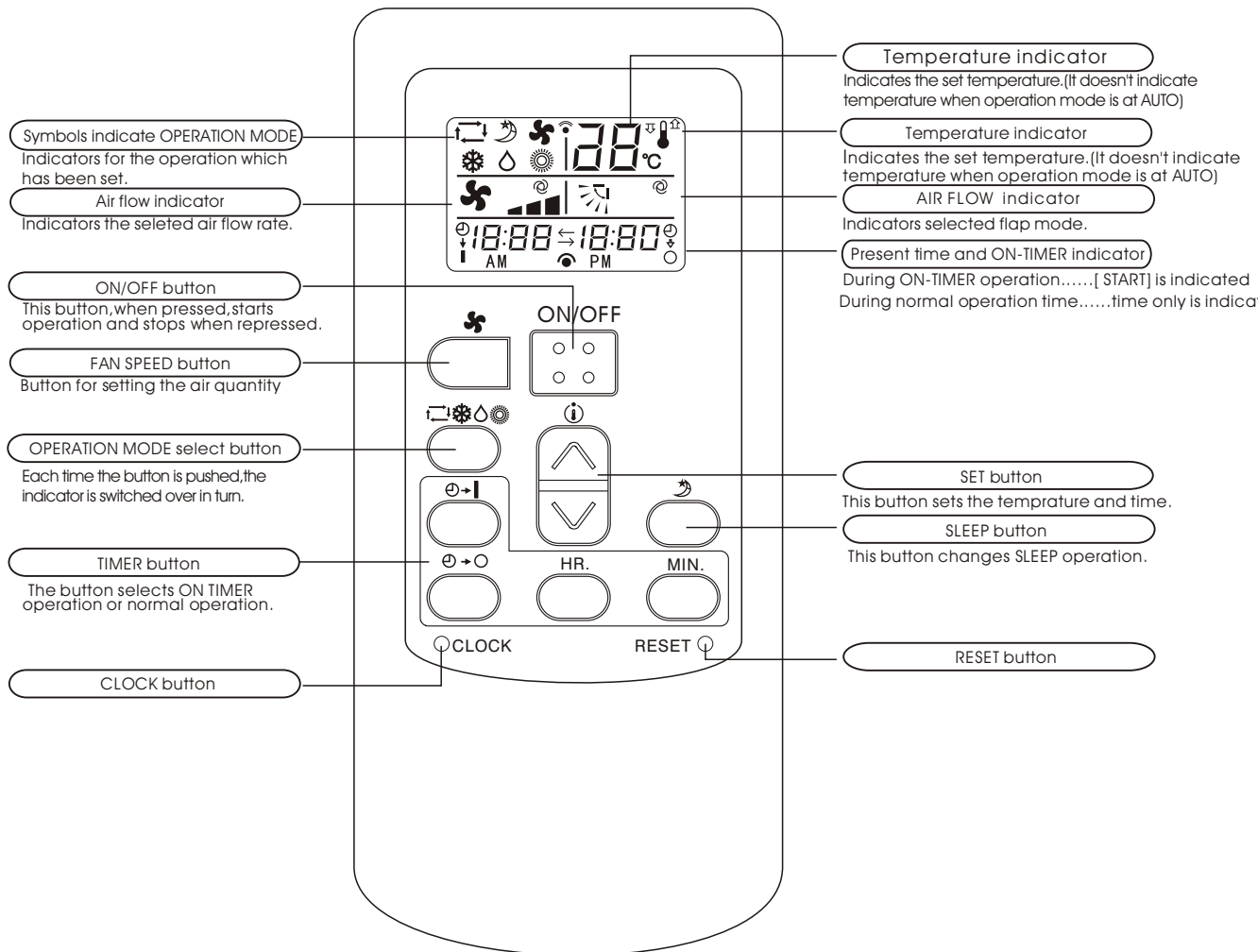

■ AUTO mode operation procedure

- Operates by selecting automatically the operation mode (HEAT, DRY, COOL) depending on the room temperature at starting.

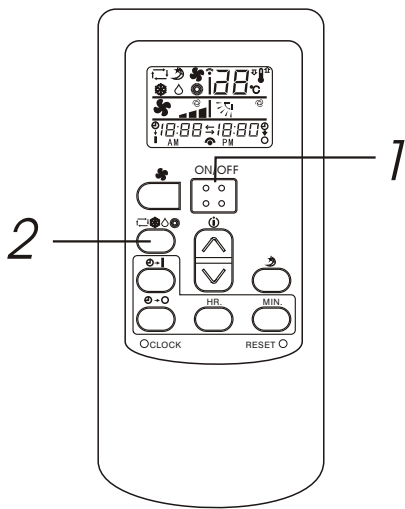

With the remote controller pointing toward the air conditioner.

1 Press the ON/OFF button.

When the unit is not at AUTO mode:

2 Press the MODE select button.
Move the MODE to the  (AUTO) position.

To Stop: Press the ON/OFF button.

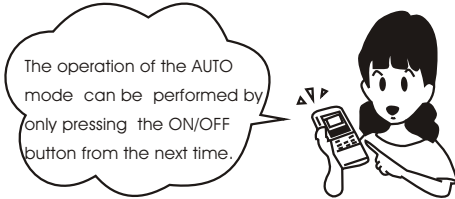



NOTE
Air is not blown out during operation.

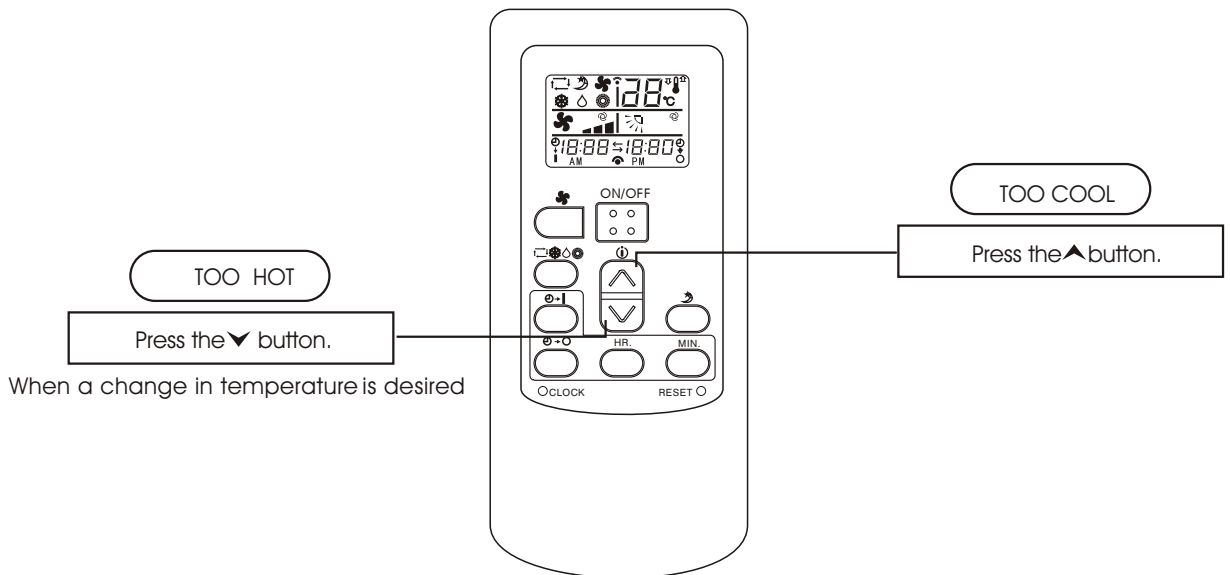

- If you don't like the content of AUTO mode operation, change to HEAT, DRY or COOL than AUTO.

■ Temperature adjusting procedure during AUTO operation

Air temperature adjustment is possible even during automatic operation. There are 6 levels of adjustment possible with the button  or the button .



1 Press the  or  button.

- In AUTO mode, the indicator default temperature is 24 °C.
- When the  button or the  button is pushed, the indicator does not change.

■ COOL/ HEAT / DRY mode operation procedure

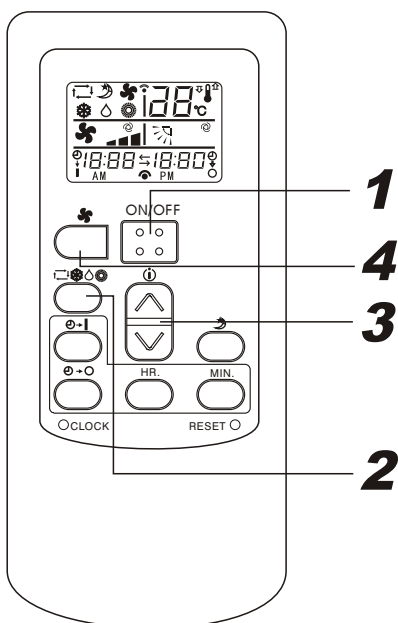

With the remote controller pointing toward the air conditioner.

- 1** Press the ON/OFF button.
- 2** Press the MODE select button.
Move the MODE to the desirable operation position.
[❄️(COOL),🔥(HEAT),💧(DRY),🌀(FAN)]
- 3** Press the TEMP. button.
Set to your favorite temperature press ▼ or ▲ button.
Standard.

COOL	26°C ~28°C	HEAT	22°C ~24°C	DRY	21°C ~24°C
------	------------	------	------------	-----	------------

 - If FAN is selected, room temperature isn't controlled, operation being continuously.
- 4** Press the FAN SPEED button.
Set to your favorite air flow rate.

NOTE

- Air is not blown out at during operation.

To Stop: Press the ON/OFF button.

- Changing procedure of the content of the operation
Set to the new content
 - The content of the operation can be set or changed even while the air conditioner is off operation.

■ Present time setting procedure

■ When cells are inserted, the present time is automatically set to AM12:00

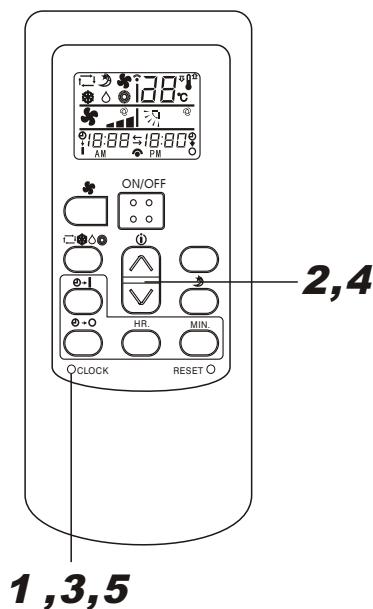

Ex: Set to AM10:30.

- 1** Please slide and remove the cover.
Press the CLOCK switch, with the tip of a ball pen, etc, the present time can be set.
- 2** Press the “▲” or “▼” button to set the “HR” .
- 3** Press the CLOCK switch again.
- 4** Press the “▲” or “▼” button to set the “MIN” .
Press within 15 sec.!
- 5** Press the clock switch to confirm.

NOTE

The timer is set on the basis of the present time. So set the present time correctly.

■ Air flow direction adjustment procedure(Some type remote controller has no this function)

Adjusting air flow direction

- Up/down direction can be adjusted by using the AIRFLOW button on the remote controller. This button, each time pressed, changes the mode in the following sequence:

- push the LOUVER button, changes the mode to swing louver. Push the button, to stop swing.

NOTE

- When the room temperature controller(thermostat)trips in the heating mode or when the defrosting operation is conducted,the blow flap changes automatically to the horizontal position.
- When the heating operation has just started and the room temperature is still low,it may take a little time before the flap moves to the above sway operation angle.
- The flap may stop at the tilted down-blow position during the "Sway operation" in the heating mode,

■ About TIMER operation

About Amenity reservation

Amenity reservation function is provided to start the operation a little earlier so that the room temperature is near the optimum temperature at the timer ON time in case of starting the operation by TIMER ON/OFF.

- Mechanism
Checking of the room temperature starts 60 minutes ahead of the timer ON time. Depending on the temperature at that time, operation starts 5 to 60 minutes ahead of the timer ON time.
- Amenity reservation is the function only for COOL and HEAT operation mode (including AUTO). It does not actuate in DRY mode.

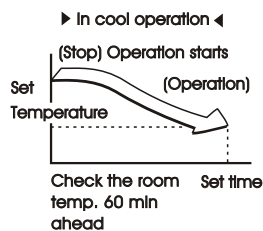

About SLEEP Operation

When the SLEEP operation is selected the room temperature is automatically controlled with elapsed time so that the room isn't too cool during cooling or too warm during heating.

- During cooling and dry: Present temperature is raised 1°C in an hour (when the timer is set), and 2°C raise in two hours. Then the temperature doesn't change ever.
- During heating: Present temperature is lowered 1°C in an hour (when the timer is set), and 2°C lower in two hours. Then the temperature doesn't change ever.

■ About FAN SPEED

- Capacity of the air conditioner can be selected by your choice during heating or cooling.

Operation capacity by your choice	FAN SPEED
Set automatically by microcomputer	AUTO
Powerful operation with high capacity	HI
Standard operation	MED
Optional	LO

■ About power-off memory function

- When the air conditioner disconnect the power supply suddenly, restart it, then the air conditioner operates at the mode it did before power suddenly failed.

Remote controller handling procedure

Batteries replacing procedure

Following cases signify dead cells. Replace the dead batteries with new ones.

- Receiving sound is not emitted from the unit when signal is transmitted.
- Indicator becomes indistinct.

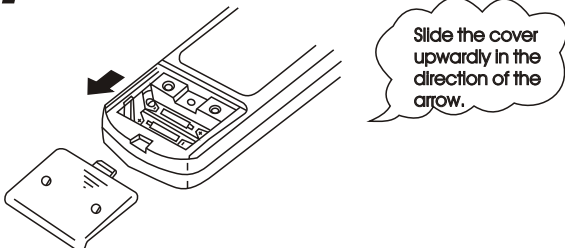
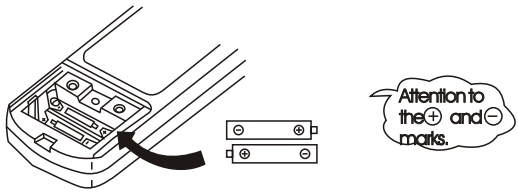



1	Please slide and remove the cover.
	
2	Exchange the batteries.
	
3	Install the cover.
4	Set it to the present time.

NOTE

- Do not use an old battery together with a new one.
- Remove cells when the remote controller is not used for a long period.
- The life of a cell made in conformity to JIS or IEC is 6 to 12 months in normal use. If it is used longer or an unspecified cell is used, a liquid leaks from the cell, causing the remote controller inoperative.

- Guideline of the life time is printed on the battery. The battery life may be shorter than that of the air conditioner depending on the date of manufacture.
- However, the battery may be alive even after the nominal life time expired.

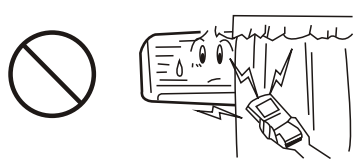
Note of remote controller handling

<ul style="list-style-type: none"> • A place with high temperature such as near an electric carpet or a stove. 	<ul style="list-style-type: none"> • A place unprotected from direct sunlight or strong lighting. 	<ul style="list-style-type: none"> • It will be damaged if falling. Be careful. 
<ul style="list-style-type: none"> • Do not put obstacles between the remote controller and the unit. 	<ul style="list-style-type: none"> • Protect the remote controller from being splashed with water, etc. 	<ul style="list-style-type: none"> • Do not put weights on the remote controller. 

TROUBLES AND CAUSES ABOUT REMOTE CONTROLLER

Before you ask for service or repairs, check the following points.

Setting change is impossible.		
Symptoms	Causes	Reason and Disposal
The fan speed can not be changed.	● Check whether the MODE indicated on the display is "AUTO".	When the automatic mode is selected ,the air conditioner automatically selects the fan speed .
	● Check whether the MODE indicated on the display is "DRY".	When dry operation is selected, the air conditioner automatically select the fan speed .The fan speed can be selected during "COOL" and "FAN ONLY",and"HEAT".
The Transmission Indicator"▲" never comes on		
Symptoms	Causes	Reason and Disposal
The remote control signal is not transmitted even when the ON/FF button is pushed.	● Check whether the batteries in the remote controller are exhausted.	The remote control signal is not transmitted,because the power supply is off.
The Display never comes On		
Symptoms	Causes	Reason
The TEMP.indicator does not come on.	●Check whether the MODE indicated on the display is "FAN ONLY".	The temperature cannot be set during fan only operation.

IMPORTANT SAFETY INFORMATION

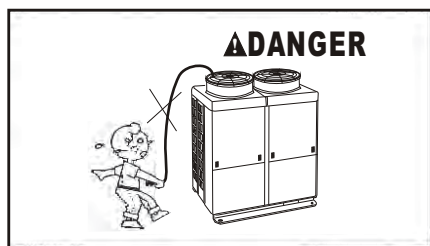

CAUTION

Do not attempt to install this unit by yourself. This unit requires installation by qualified persons.

DANGER

Do not attempt to service the unit yourself. This unit has no user serviceable components. Opening or removing the cover will expose you to dangerous voltage. Turning off the power supply will not prevent potential electric shock.

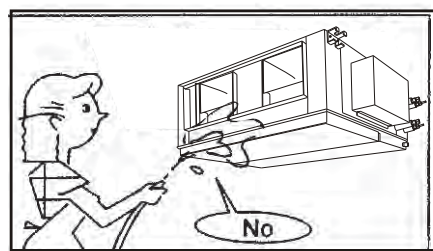

DANGER

Never put hands or objects into the air outlet of indoor or outdoor units. These units are installed with a fan running at high speed. To touch the moving fan will cause serious injury.

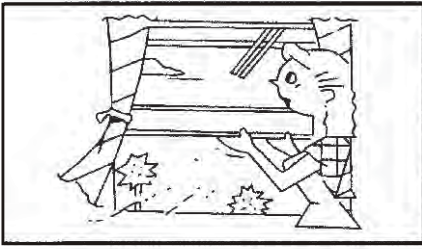
**⚠ DANGER**

To avoid the risk of serious electrical shock. Never sprinkle or spill water or liquids on unit.

**⚠ WARNING**

Ventilate the room regularly while the air conditioner is in use, especially if there is also a gas appliance in use in this room. Failure to follow these directions may result in a loss of oxygen in the room.

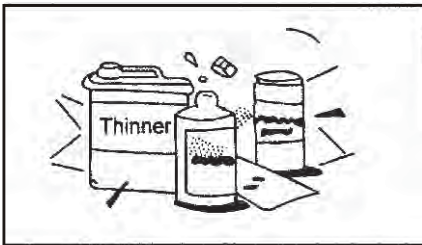
**⚠ WARNING**

To prevent electric shock, turn off the power or disconnect the power supply plug before beginning any cleaning or other routine maintenance.

**⚠ WARNING**

Do not use liquid cleaners or aerosol cleaners, use a soft and dry cloth for cleaning the unit. To avoid electric shock, never attempt to clean the units by sprinkling water.

⚠ CAUTION

Do not use caustic household drain cleaners in the unit. Drain cleaners can quickly destroy the unit components (drain pan and heat exchanger coil etc).

⚠ NOTE

For proper performance, operate the unit in temperature and humidity ranges indicated in this owner's manual. If the unit is operated beyond these conditions, it may cause malfunctions of the unit or dew dripping from the unit.

These are not failures

Room air is smelly.

A bad odor comes from the air conditioner.

- Smells impregnated in the wall, carpet, furniture, clothing, or furs, are coming out. A white mist of chilled air or water is generated from the outdoor unit.

⚠ CAUTION

If any of the following conditions occur, stop the air conditioner immediately, set off the power switch, and contact the dealer.

- The indicator lamps flash rapidly (five times per second), you disconnect the unit with the power and then connect the unit with the power again after two or three minutes but the lamps still flash.
- Switch operations are erratic.
- The fuse is blown frequently or the circuit breaker is tripped frequently.
- Foreign matter or water has fallen inside the air conditioner.
- Any other unusual condition is observed.

INDOOR UNIT INSTALLATION

Pre-installation precautions

- Please confirm that the installation personnel are qualified in relevant installation service. If the air conditioner was installed by persons without special skills, normal operations would not be ensured, even the personal and estate safety would be affected

The air conditioner must be correctly installed by installation technicians according to the attached 《Installation Manual》, and the user himself should not install it.

User guideline

- The user's installation site should be provided with regular power supply in conformity with that indicated in nameplate of the air conditioner, and its voltage should be within a range 90% ~ 110% of the rated voltage value.
- Power circuit should be equipped with protector, such as electricity leakage protector or air switch, which should possess a capacity greater than 1.5 times the maximum current value of the air conditioner.
- Never fail to adopt personal circuit and effectively-grounded socket compatible with the attached plug of the air conditioner. The attached plug is equipped with grounding pin, and it must not be modified as desired.
- Please adopt the fuse or circuit breaker prescribed in Installation Instructions.
- Only qualified electrician is allowed to carry out wiring tasks strictly according to electric safety requirements.
- Do ensure good earth of air conditioner, in other words, the main power switch of air conditioner must be connected to reliable ground wire

Precautions

- The air conditioners should be installed securely; otherwise poor installation may lead to abnormal noises and vibration.
- Outdoor unit should be installed at a spot ensuring that its air outlet noises and hot exhaust will not violate your neighbors.

Installation method for indoor unit

1. Pendant installation of indoor unit

- Installation mode of indoor unit must ensure minimum length of system pipeline and air conduit, therefore the Indoor unit should be installed at medium position of a suite.
- Ensure adequate strength of the top suspension rod so as to withstand weight of the unit. Determine the position of suspension rod, align it to pendant-mounting hole in the unit, and then tighten it (for position of suspension rod, see outline dimensional drawing for the unit)
- Check the installation levelness of the unit, and set the drainage slope according to dimensions listed in figure below (Gradient greater than 1/100)

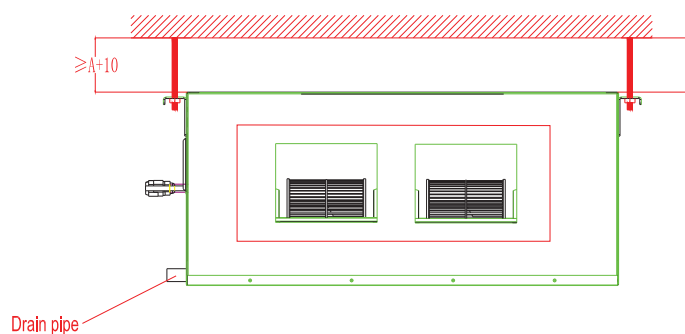

2. How to mount outlet pipe

- Generally, we have two types of outlet pipe available, i.e. rectangular or round ones.
- Rectangular air conduit can be directly connected to air outlet of indoor unit by rivets. For outlet dimensions, see outline drawing of the unit.
- Round air conduit should be connected to a piece of transitional air conduit before it is connected to air outlet of indoor unit, the other end of it can be separately connected to air conduit window or connected to air conduit window after air flow diversion, and the total length should not be over 6m. As shown in figure below, air speeds at all air outlets should be set to basically consistent so as to meet the room air-conditioning requirements.

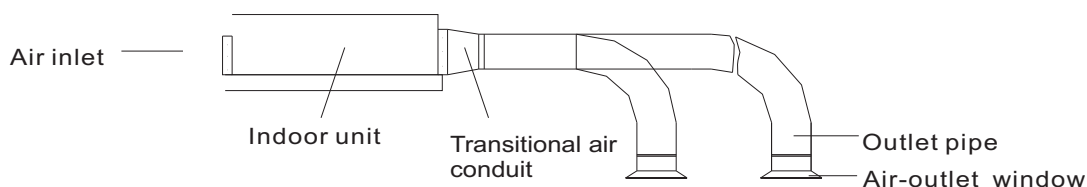

3. Installation method for return air pipe

- In case sidewise air intake is adopted, return air pipe should be fabricated and rivet-connected to return air orifice, and the other end of it should be connected to return air window.
- In case of underside air intake, purchase or fabricate a section of pleated canvas air conduit serving as transition joint for return air orifice and return air window. In this way, it can be freely adjusted according to height of indoor ceiling board; in addition, during operation of the unit, canvas air conduit may avoid vibration of ceiling board, as shown in figure below.

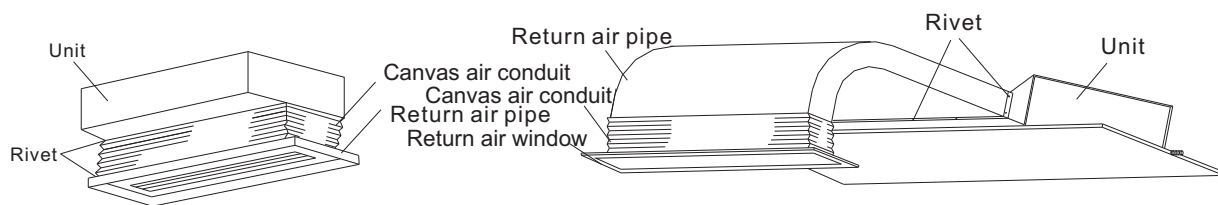

Installation mode for underside air intake

Installation mode for sidewise air intake

4. Tips for installation of return air pipe and outlet pipe

- To minimize energy loss occurring in transmission process and condensed water during heating operation, return air pipe and outlet pipe should be equipped with heat-insulating layer as shown in the figure.

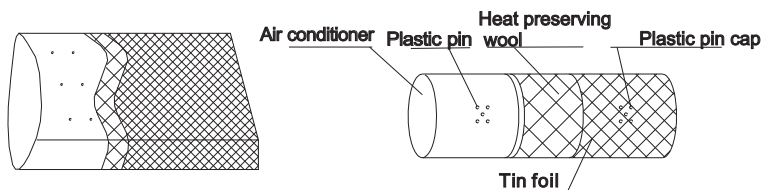

- Return air pipe and outlet pipe should be fixed to floor precast slabs by iron stand; in addition, all ports of the air conduit should be tightly sealed by gasket cement, and it is advisable that the edge clearance of return air pipe should be 150mm at least.

- Drain pipe for condensed water should be installed with minimum gradient of 1 %, and the drain pipe should be insulated with heat-preserving pipe casing as well.

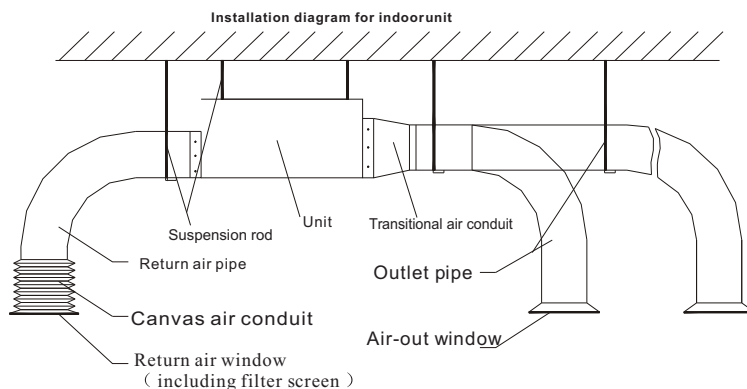

Dimension

(1) The relationship between the ceiling opening of indoor unit and the location of hanging bolts.

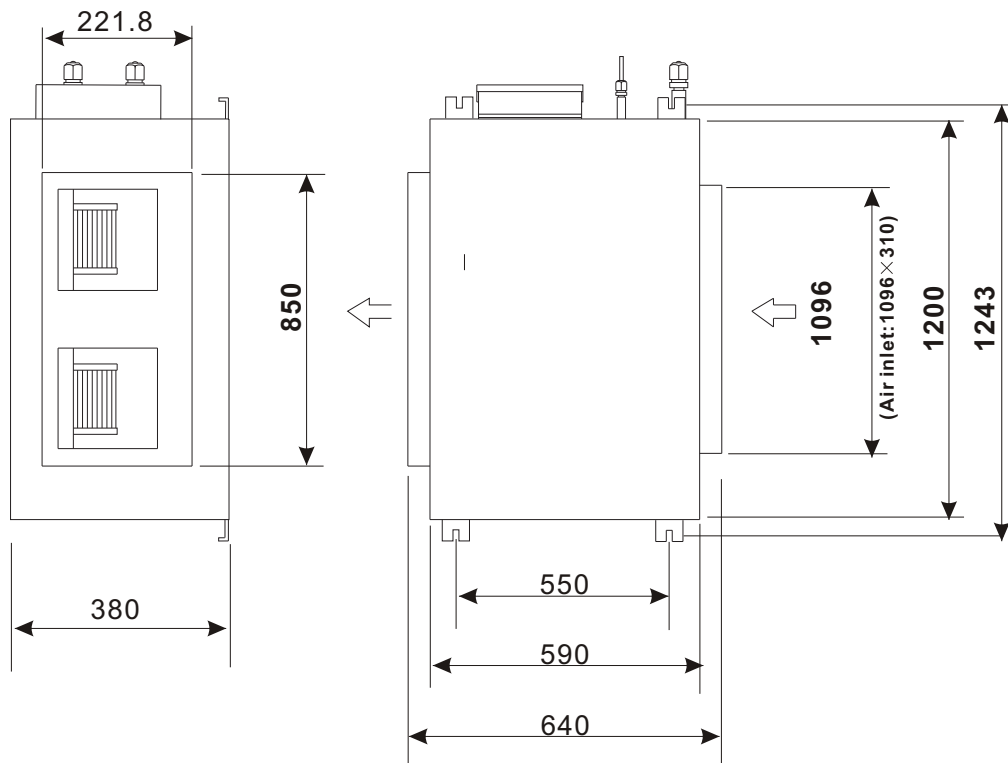

(2) Install hanging bolts

If the ceiling have been builded, please use anchor bolts. For the newly-built ceiling, please use embedded fixed plate, embedded anchor bolts or other locally purchased parts to reinforce the ceiling, ensure that it is hard enough to support the weight of the indoor unit.

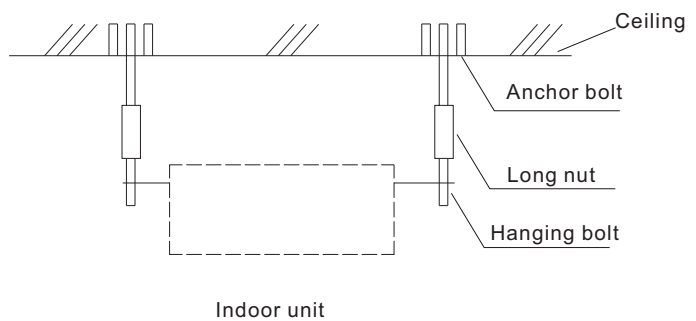

OUTDOOR UNIT INSTALLATION

● Location for installing outdoor unit

1. Install it at a place where it is convenient for installation and well ventilated.
2. Keep the required distance away from the wall as required on the previous page when carrying on installation.
3. Pipe length and drop height should comply with the scope required below.

12kW, 15kW

Max pipe length	25m
Max drop height L	10m
Max. bending No.	5

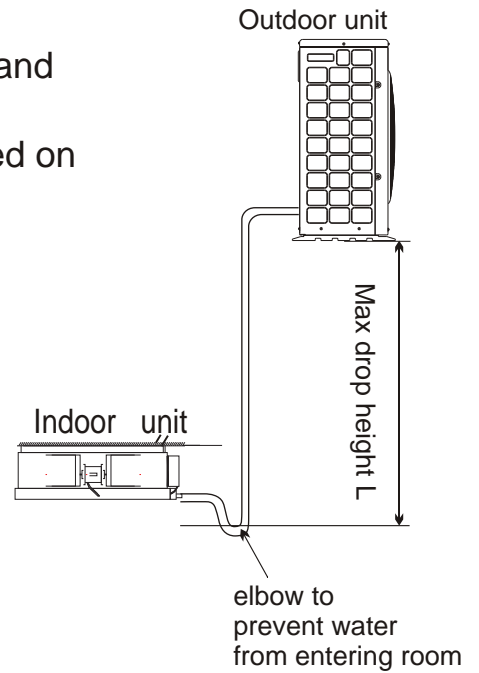

4. When operating at a special place, for example, a place of greasy dirt, vulcanization gas or high-salty seashore, make sure to adopt an effective isolation measure.
5. Avoid installing it on the roadside where there is a risk of muddy water.
6. Install it where your neighbors would not be annoyed by operating noise or discharged hot air.
7. Install it on a fixed shelf that is not subject to increasing noise.
8. Install it at a place without blockage for air outlet.

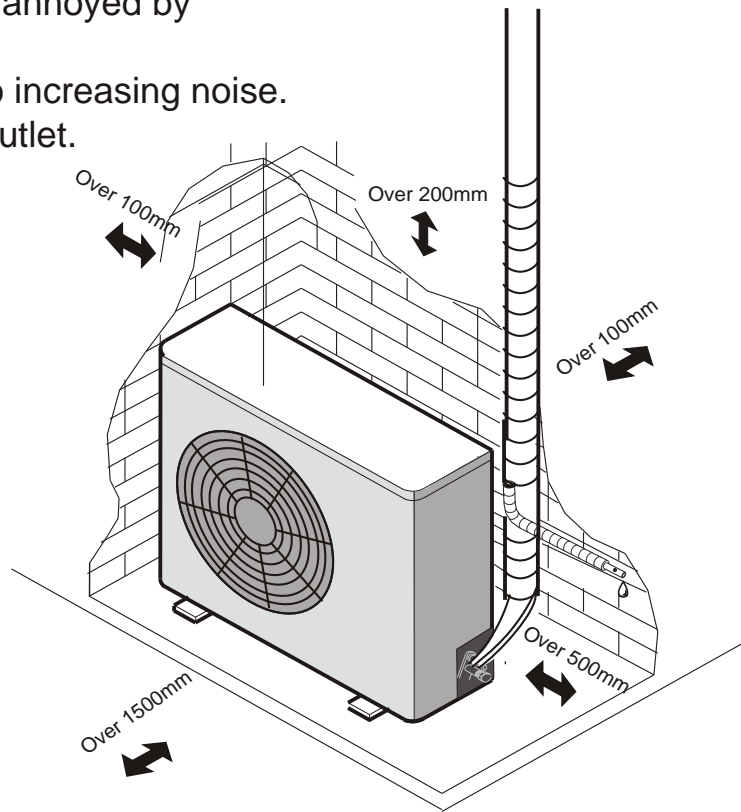
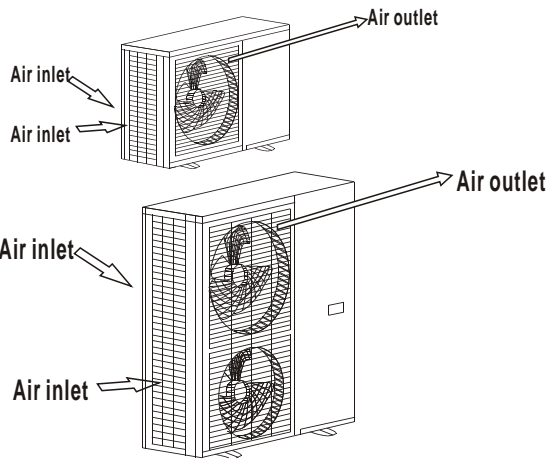

● Sketch of installation as following:

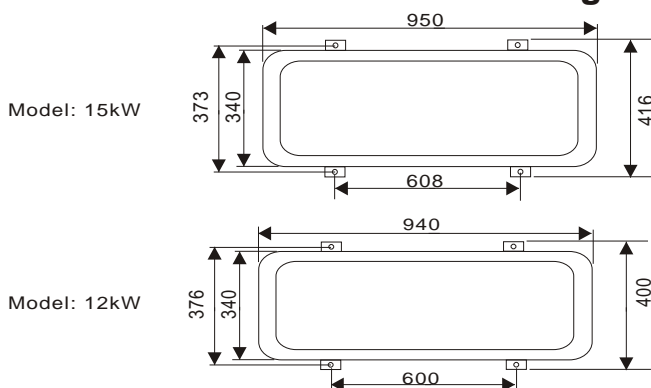

- Please install the air conditioner according to international rules.
- Above figures are only a simple presentation of the unit, it may not match the external appearance of the unit you purchased.

REFRIGERANT PIPE INSTALLATION



Ventilate the air if there was any refrigerant leakage during the installation.

Leaked refrigerant will generate poisonous gas if meeting fire.



Make sure there is no refrigerant leakage after the installation.

Leaked refrigerant will generate poisonous gas if meeting fire.



Allowed Length and Drop of Pipes

Requirements are different when installing the outdoor unit.

Material and Size of the Pipes

Three length (3m,5m,10m) of pipes are available to purchase.

Pipe Material		Copper Pipe for Air Conditioner	
Model		FG Y 4F1 \ Y	
Size(mm)	Liquid side	12.7(1/2inch)	
	Gas side	19.05(3/4inch)	

Additional refrigerant charge

The additional charge is base on the diameter and length of outlet/inlet liquid type .
This AC has been charged with that for 5m pipe, those beyond 5 m should recharge as follows.

Liquid pipe diameter	ϕ 1/4 "	ϕ 3/8 "	ϕ 1/2 "
Additional charge for 1m pipe(R410A)	0.022kg	0.054kg	0.110Kg

Connection of the Refrigerant Pipe

- Double-span should be used when connecting the pipes.
- The wrench torque follow the below table:

Pipe external diameter	Added wrench torque (N.m)	Pipe external diameter	Added wrench torque (N.m)
	14.2(1.4kgf.m)~17.0 (1.7kgf.m)	12.7	49.5(5.04kgf.m) ~60.3(6.16kgf.m)
9.52	32.7(3.33kgf.m) ~39.9(4.07kgf.m)	19.05	97.2(9.9kgf.m)~118.6(12.1kgf.m)
15.88	61.8(6.3kgf.m)~75.4(7.7kgf.m)		

Wrap the piping

- Wrap the connecting pipes and cables together with tape, but not including the drainage pipe. Drainage pipe can be fixed along them separately.
- Wrapping from the joint of outdoor unit to that of indoor unit, each round of tape should cover half of its previous one.

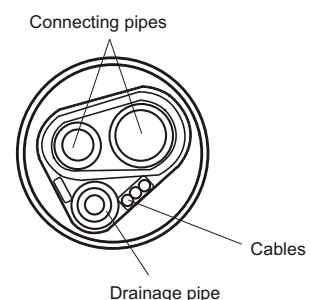

DRAINAGE PIPE INSTALLATION

CAUTION

Be sure to follow this Installation Manual during drainage installation, the drainage pipe must have the heat insulation to prevent condensing.



- The drain pipe of indoor unit must have the heat insulation, or it will condense dew, as well as the connections of the indoor unit.
- The declivity of the drain pipe downwards should not be over 1/100, and no winding and bending.
- The total length of the drain pipe when pulled out transversely shall not exceed 20m, when the pipe is over long, a prop stand must be installed every 1.5 to 2m to prevent winding.
- Refer to the following figures about the installation of the pipes.
- Do not impose any pressure on the connection part of the drainage pipe.

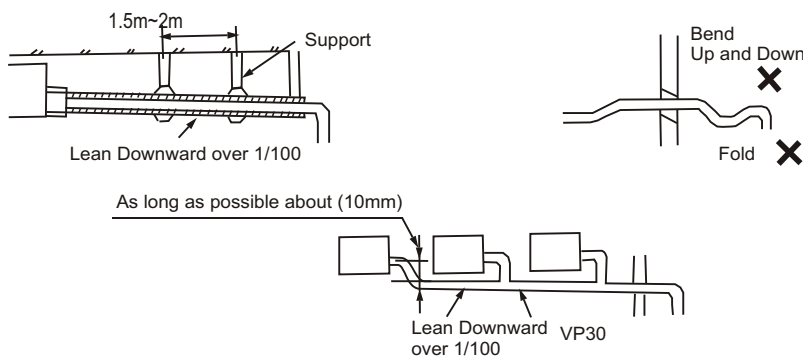

Drainage Pipe Material, Heat-insulating Material

The listed material should be used:

Drainage Pipe Material	Polyvinyl chloride pipe (32mm outer diameter)
Heat Insulation Material	Foamed polyethylene insulation plate (10mm thickness)

Connection Procedure

Connect the transparent pipe with the polyvinyl chloride pipe.

- Use polyvinyl chloride glue at the connection part of the drainage pipe, be sure no water leakage.
- Paste glue at the front 40mm of the polyvinyl chloride pipe, insert it into the transparent pipe.
- It needs 10 minutes for the glue to dry. Do not impose pressure on the connection during the drying period.

Heat Insulation

Wrap the flexible hose carefully with the attached heat insulation material from the start to the end (to indoor part)

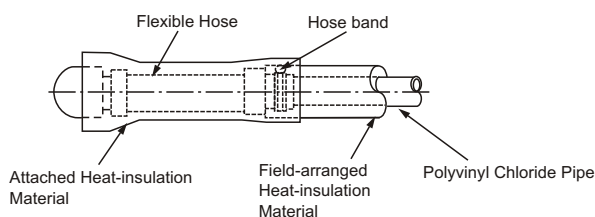

ELECTRIC WIRING

WARNING

Specified power cables should be used. Do not apply any pressure on the terminals used to connect.

Improper connection may cause fire.



Grounding must be properly done.

The grounding wire should be away from gas pipes, water pipes, telephone, lightning rods or other grounding wires. Improper grounding may cause electric shock.



Electric Wiring must be done by professionals. Use a separate circuit according to national regulations.



The temperature of refrigerant circuit will be high, please keep the interconnection cable away from the copper tube.

If the wiring capacity is not enough, electric shock or fire may occur.

If the supply cord is damaged, it must be replaced by the manufacturer or its service agent or a similarly qualified person in order to avoid a hazard.

An all-pole disconnection switch having a contact separation of at least 3mm in all poles should be connected in fixed wiring.

CAUTION

Be sure to Install Current Leakage Protection Switch. Or electric shock may occur.

- Power cord is to be selected according to national regulations.
- Outdoor unit power cord should be selected and connected according to the outdoor unit installation manual.
- Wiring should be away from high temperature components, or the insulation layer of the wires may melt down.
- Use wire clamp to fix the wires and terminal block after connection.
- Control wire should be wrapped together with heat insulated refrigerant pipes.
- Connect the indoor unit to power only after the refrigerant has been vacuumed.
- Don't connect the power wire to the signal wire connection end.

Notice

1. Power cord indicates the supply cable from indoor air switch to indoor unit or outdoor unit.
Indoor/outdoor power connecting wire indicates the supply cable connecting indoor unit and outdoor unit.
2. Cross-section area of power cord wire is the minimum value here. In case power-connecting wire is longer than usual, just select the conductor cross-section a level higher than the specified one to avoid voltage drop.
3. The cross section of ground wire for the whole set of air conditioner should be 2 mm² at least.
Power cord connected to indoor unit should be cable RVV (300 / 500); the power cord connected to outdoor unit and the indoor/outdoor power connecting wire should be multi-wire strand cable (neoprene) YZW (300 / 500V).
4. In case single-core double-layer wire is adopted, its cross section should be one level bigger than the specified one, and the wire should be covered with dedicated electric sheath.

1. Wiring method for indoor unit: Open the electric junction box to carry out wire connection. Notice that the connecting wire should be passed through wire-inlet rubber ring of the box. Connect the wires according to stipulations in the wiring diagram, and the wire splices at connecting terminal should be tightly compacted, free of looseness.

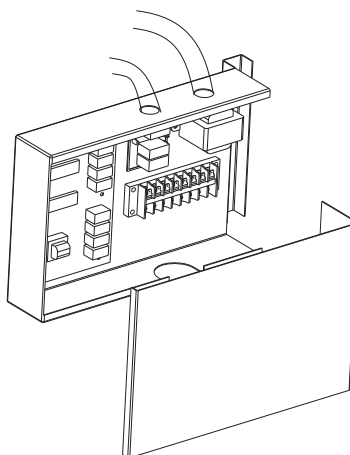

2. Binding treatment

Once the connecting wires have been properly connected, bind the connecting tubing, connecting wire and drain pipe by binding tapes

After binding treatment, the cross section is shown in the figure below:

Notice: Drain pipe must not be flattened during binding treatment.

Drain pipe outlet should be led to a place that can avoid affecting the environment.

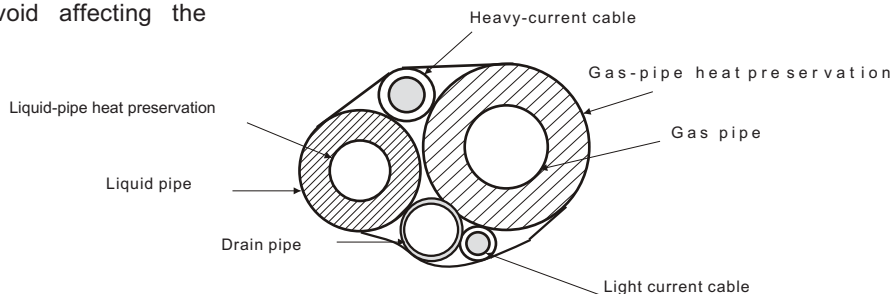

TRY TEST

Before testing

- a. Check if piping, drainage and external wiring have been finished correctly.
- b. Check if the power supply complies with requirements; if there is refrigerant leakage; if the all wires and cables are correctly connected and well fixed.

■ Function test

- a. After checking, energize your appliance and press the buttons on the control panel to see if the buttons function;
- b. If LCD screen displays normally.

■ Notes

1. Please read this operating and installation instructions carefully.
2. Do not let air in or refrigerant out during installing or reinstalling the appliance.
3. Test run the air conditioner after finishing installation and keep the record .
4. Type of fuse for controller of indoor unit is 50T, rated specification is T 5 A, 250V. Fuse for the whole unit is not supplied by the manufacturer, so the installer must employ a suitable fuse or other over-current protective device for the power supply circuit according to the maximum power input as required.
5. The air conditioner operates safely when ambient static pressure is 0.8~1.05 standard atmosphere pressure.

TROUBLESHOOTING

Trouble display of indoor display panel

Num	Type	Contents	LED Flashing	Notes
1	Trouble	Room temp sensor abnormal	TIMER lamp flashing at 5Hz	Recover automatically after troubles are eliminated.
2	Trouble	Evaporator temp sensor abnormal	OPERATION lamp flashing at 5Hz	
3	Trouble	Condensor temp sensor abnormal	PRE/DEF lamp flashing at 5Hz	
4	Trouble	Outdoor protection	PRE/DEF and ALARM lamp flashing at 5Hz	Recover after power up again
5	Trouble	EEPROM communication trouble	OPERATION and TI MER lamp flashing at 5Hz	

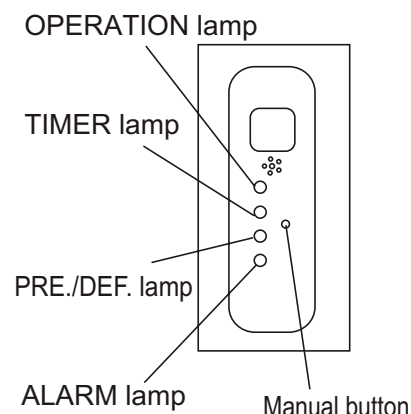

Action:

- Room temp sensor abnormal, evaporator temp sensor abnormal or condensor temp sensor abnormal
 - a. Please test the resistance of sensor by multimeter to ensure the resistance of this sensor is subject to the resistance data indicated in appendix ;
 - b. If the resistance is all right, please test the resistance of pull-down resistor at sensor interface by multimeter to ensure that it is in the range of 8.1k-10k, and measure the sampling port voltage of IC sensor by multimeter to ensure that it is about 3V;
 - c. If the voltage and resistance measured are out of the range mentioned in step 2 above, please replace a new main PCB.
- Outdoor protection

Please check the outdoor unit.
- EEPROM communication trouble

Please replace the main PCB..

CAPACITY CORRECTION FACTOR

1. Capacity correction factor of pipe length

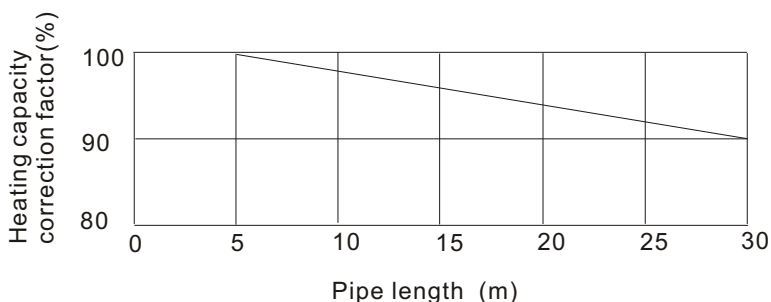
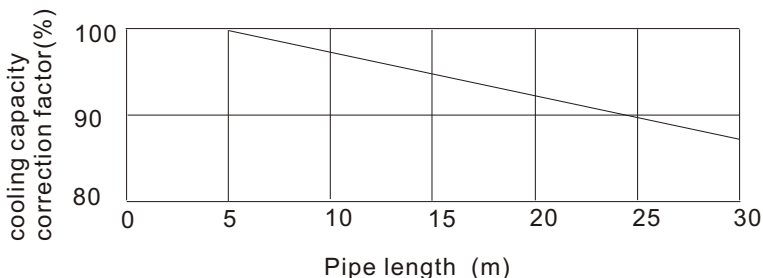

2. Temperature-capacity curve

(1) Outdoor temperature - Cooling capacity curve

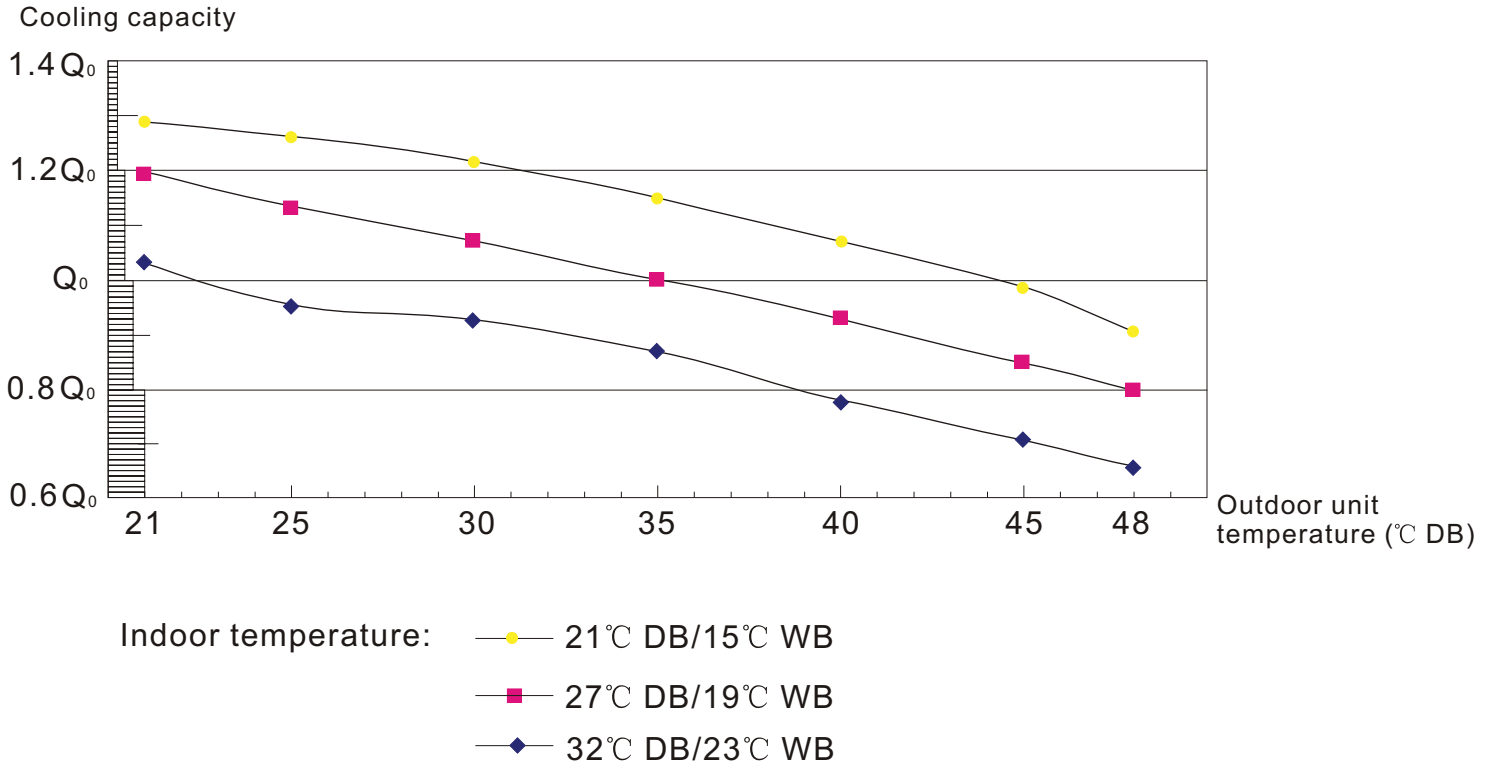

(2) Outdoor temperature - Heating capacity curve

Heating capacity Indoor temperature: 20°C DB/15°C WB

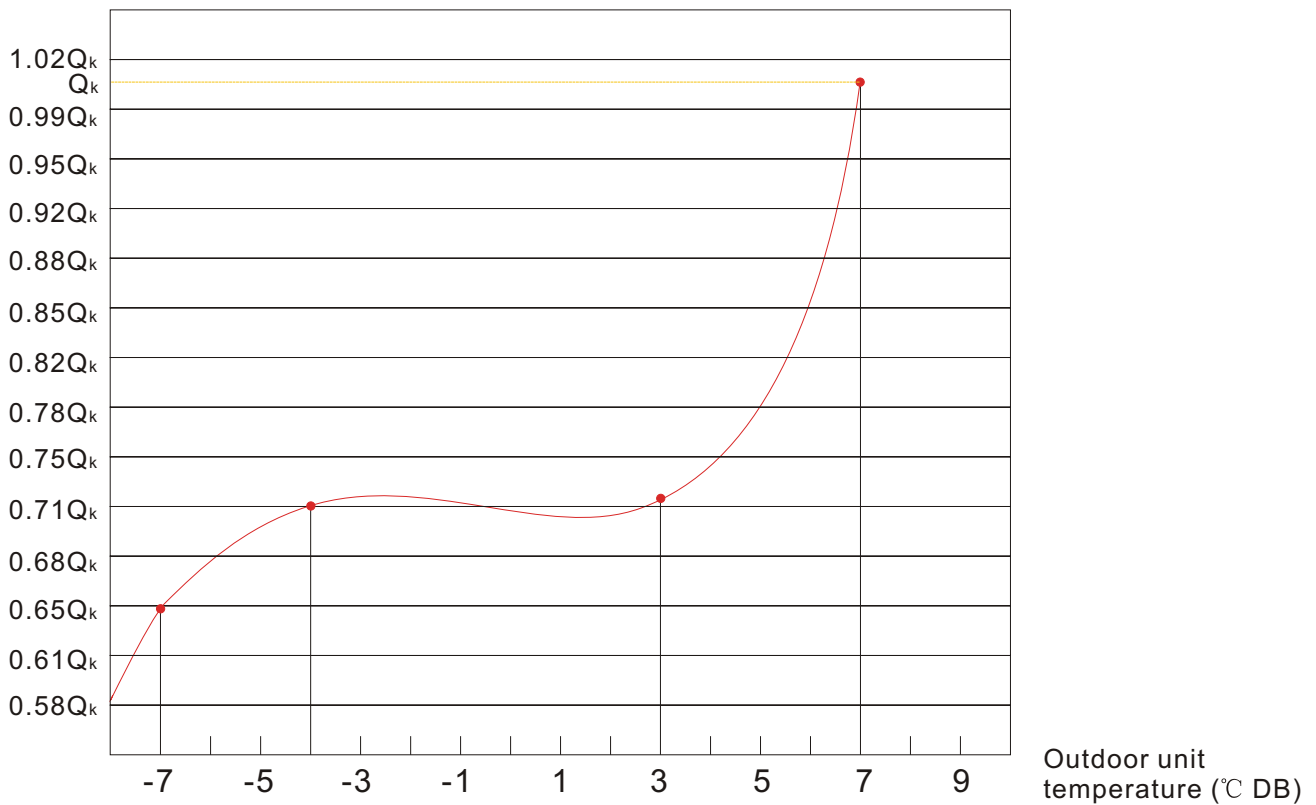

AIR FLOW AND STATIC PRESSURE

Model:FG Y

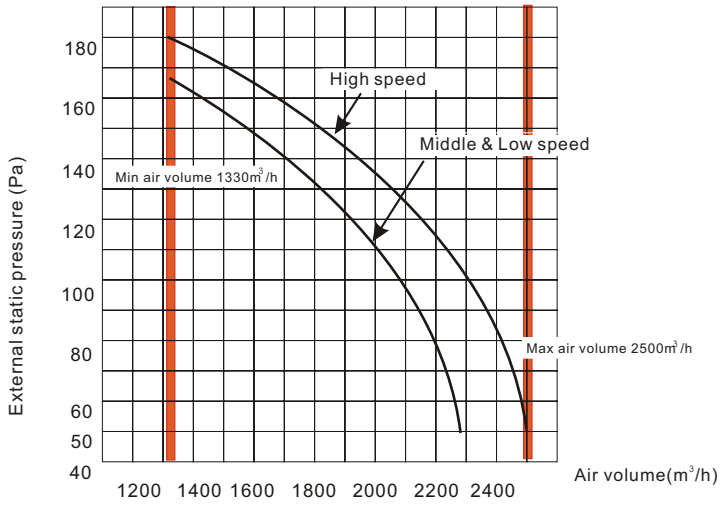

Model:FÍ \ Y

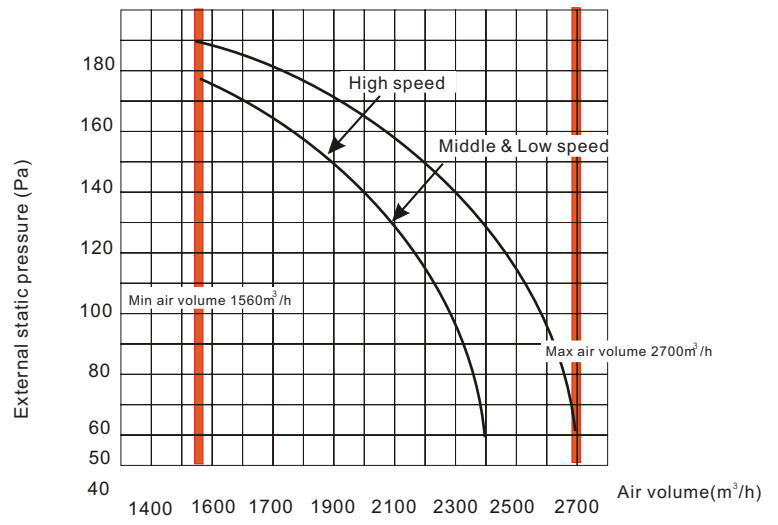

Detailed specifications				
Model No.			8 U	8 I
Type			Heating Pump	Heating Pump
Control type			Remote Controller & Wire controller	
Static pressure	Standard	Pa	50	50
	Range		50~180	50~180
Cooling capacity		Btu/h;W	36000;11500	48000;14000
Heating capacity		Btu/h;W	38000;12000	50000;15000
EER for cooling		Btu/h.w; W/W	8.78;2.76	9.38;2.75
COP for heating		Btu/h.w; W/W	10.9;3.46	11.8;3.45
Indoor noise level at cooling(sound pressure level)	High	dB(A)	53	53
	Med.	dB(A)	52	52
	Low	dB(A)	51	51
Outdoor noise level(sound power level)		dB(A)	65	65
Electrical Data				
Power supply			220-240V~/50Hz/1P	220-240V~/50Hz/1P
Voltage Range		V	198~254	198~254
Current	Cooling	A	18	22
	Heating	A	17.4	20.4
Power input	Cooling	W	4150	5050
	Heating	W	4000	4700
Max. Power		W	5865	6850
Max. Current		A	25.5	29.8
Refrigerating System				
Refrigerant			R410A	R410A
Evaporator			Hydrophilic & Louver Fin; Innergroover tube type (φ9.52)	
Condenser			Louver or Corrugated Fin; Innergroover tube type (φ7)	
Expansion device			Capillary tube	
Defrosting system			Microcomputer controlled reverse system	
Fan System				
Outlet size of indoor airflow		mm	855x220	855x220
Returning vent size of indoor airflow		mm	1096x310	1096x310
Indoor air circulation(Cooling/Heating)		L/S	695/630/630	750/667/667
		m ³ /h	2500/2270/2270	2700/2400/2400
Indoor fan type			Centrifugal	Centrifugal
Outdoor fan type			Propeller	Propeller
Connections				
Refrigerant coupling			Flare	Flare
Connecting Pipe	Liquid	Inches	1/2"	1/2"
	Gas	Inches	3/4"	3/4"
Max. height drop (high head)		m	10	10
Max. length of connecting pipe		m	25	25
Max. pipe length with standard charge		m	5	5
Refrigerant charge with long pipe		g/m	110	110
Drainage Pipe		mm	O.D 16	O.D 16
Others				
Net dimensions (W x H x D)	Indoor	mm	1200x380x590	1200x380x590
	Outdoor	mm	950x1255x410	940x1245x340
Net weight	Indoor	kg	55	58
	Outdoor	kg	112	126
Packing dimension (W x H x D)	Indoor	mm	1410x445x695	1410x445x695
	Outdoor	mm	1030x1380x440	1065x1400x435
Gross weight	Indoor	kg	60	63
	Outdoor	kg	122	132
Loading Capacity		20'/40'/40'HC	25/50/50	24/48/48
Note				
Specifications are based on the following conditions:				
Cooling: Indoor temperature 27 °C DB/19°C WB, and outdoor temperature 35 °C DB/24°C WB.				
Heating: Indoor temperature 20 °C DB/15°C WB, and outdoor temperature 7 °C DB/6°C WB.				
Equivalent piping length: 5m; Level difference:0m;				
Sound Level: Indoor unit sound pressure level, measured at a point 1.5m downward from the unit center.				
Outdoor unit sound pressure level, measured at a point 1.0m in front of the unit.				
Optional simple wired controller; Universal remote controller; auto-restart(optional); Timer:only one circle.				
Due to ongoing product development, specifications are subject to change without prior notice.				

Mapping table of temperature sensor

B25/50=4100±1%**R(25°C)=10K**

Centigrade	Resistance	Fahrenheit	Centigrade	Resistance	Fahrenheit	Centigrade	Resistance	Fahrenheit
-20	115.2660	-4.0	26	9.5507	78.8	72	1.5367	161.6
-19	108.1460	-2.2	27	9.1245	80.6	73	1.4848	163.4
-18	101.5170	-0.4	28	8.7198	82.4	74	1.4350	165.2
-17	96.3423	1.4	29	8.3357	84.2	75	1.3870	167.0
-16	89.5865	3.2	30	7.9708	86.0	76	1.3111	168.8
-15	84.2190	5.0	31	7.6241	87.8	77	1.2908	170.6
-14	79.3110	6.8	32	7.2946	89.6	78	1.2542	172.4
-13	74.5360	8.6	33	6.9814	91.4	79	1.2133	174.2
-12	70.1698	10.4	34	6.6836	93.2	80	1.1739	176.0
-11	66.0898	12.2	35	6.4002	95.0	81	1.1360	177.8
-10	62.2756	14.0	36	6.1306	96.8	82	1.0996	179.6
-9	58.7079	15.8	37	5.8736	98.6	83	1.0645	181.4
-8	56.3694	17.6	38	5.6296	100.4	84	1.0307	183.2
-7	52.2438	19.4	39	5.3969	102.2	85	0.9982	185.0
-6	49.3161	21.2	40	5.1752	104.0	86	0.9668	186.8
-5	46.5725	23.0	41	4.9639	105.8	87	0.9366	188.6
-4	44.0000	24.8	42	4.7625	107.6	88	0.9075	190.4
-3	41.5878	26.6	43	4.5705	109.4	89	0.8795	192.2
-2	39.8239	28.4	44	4.3874	111.2	90	0.8525	194.0
-1	37.1988	30.2	45	4.2126	113.0	91	0.8264	195.8
0	35.2024	32.0	46	4.0459	114.8	92	0.8013	197.6
1	33.3269	33.8	47	3.8867	116.6	93	0.7771	199.4
2	31.5635	35.6	48	3.7348	118.4	94	0.7537	201.2
3	29.9058	37.4	49	3.5896	120.2	95	0.7312	203.0
4	28.3459	39.2	50	3.4510	122.0	96	0.7094	204.8
5	26.8778	41.0	51	3.3185	123.8	97	0.6884	206.6
6	25.4954	42.8	52	3.1918	125.6	98	0.6818	208.4
7	24.1932	44.6	53	3.07075	127.4	99	0.6186	210.2
8	22.5662	46.4	54	2.9590	129.2	100	0.6297	212.0
9	21.8091	48.2	55	2.8442	131.0			
10	20.7184	50.0	56	2.7382	132.8			
11	19.6891	51.8	57	2.6368	134.6			
12	18.7177	53.6	58	2.5397	136.4			
13	17.8005	55.4	59	2.4168	138.2			
14	16.9341	57.2	60	2.3577	140.0			
15	16.1156	59.0	61	2.2725	141.8			
16	15.3418	60.8	62	2.1907	143.6			

Centigrade	Resistance	Fahrenheit	Centigrade	Resistance	Fahrenheit	Centigrade	Resistance	Fahrenheit
17	14.6181	62.6	63	2.1124	145.4			
18	13.9180	64.4	64	2.0373	147.2			
19	13.2631	66.2	65	1.9653	149.0			
20	12.6431	68.0	66	1.8963	150.8			
21	12.0561	69.8	67	1.8300	152.6			
22	11.5000	71.6	68	1.7665	154.4			
23	10.9731	73.4	69	1.7055	156.2			
24	10.4736	75.2	70	1.6469	158.0			
25	10.0000	77.0	71	1.5907	159.8			